

SensyTemp TSP311, TSP321, TSP331 Temperature sensors

Sturdy and versatile

Measurement made easy



Heavy-duty design

Modular design

- Measuring inset, thermowell, extension tube, connection head, transmitter

Extremely robust connection head

- Aluminum or stainless steel screw-on cap for offshore applications

Transmitter in connection head

- Optional LCD indicator
- Optional display function (type AS) or display with configuration function (type A)
- SIL 2 for transmitter

Approvals

- SIL 2 for sensors with integrated transmitter
- IECEx
- ATEX
- EAC Ex (GOST)

Areas of application

- Offshore and coastal areas
- Petroleum and natural gas production and transport
- Petrochemical industry
- Chemical industry
- Energy industry

SensyTemp TSP311, TSP321, TSP331 Temperature sensors

Overview of temperature sensors

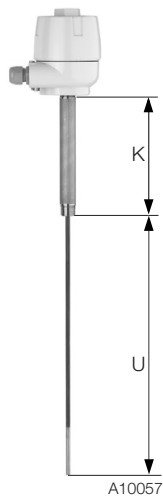
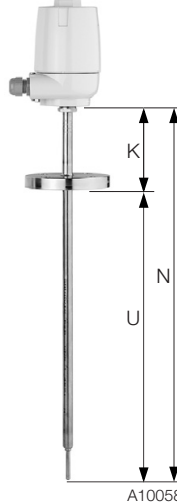
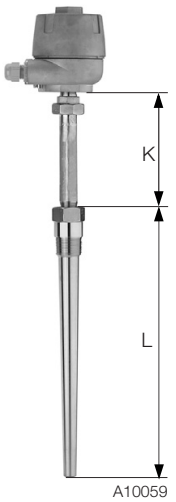
Type	TSP311	TSP321	TSP331
Legend: K = Extension tube length U = Installation length N = Nominal length L = Thermowell length	 <p>A10057</p>	 <p>A10058</p>	 <p>A10059</p>
Design	No thermowell, for installation in existing thermowell	Welded protective fitting manufactured from pipe material	Drilled thermowell manufactured from bar stock material
Process connection	Insertion in an existing thermowell. Functional reliability is only assured with an additional thermowell!	Screw-in thread, flange, compression fitting	Welded connections, screw-in thread, flange
Transport temperature / Storage temperature	-20 ... 70 °C (-4 ... 158 °F)		
Maximum temperature limits	(depending on the sensor and material selected, the lower temperature value in each case counts)		
Sensor	Thin film resistor: 400 °C (752 °F), wire wound resistor: 800 °C (1472 °F), Thermocouples type K, N, J, E, L, S: 1600 °C (2912 °F)		
Material (other materials on request)	316L / 1.4404	≤ 800 °C (1472 °F)	
	316Ti / 1.4571	≤ 800 °C (1472 °F)	
	Inconel 600 / 2.4816	≤ 1100 °C (2012 °F)	≤ 1100 °C (2012 °F)
	Hastelloy C276 / 2.4819	–	≤ 1100 °C (2012 °F)
	Monel 400 / 2.4360	–	600 °C (1112 °F)
	1.7335	–	≤ 540 °C (1004 °F)
	1.7380	–	≤ 570 °C (1058 °F)
	1.5415	–	≤ 500 °C (932 °F)
E-CTFE	–	≤ 120 °C (248 °F)	≤ 120 °C (248 °F)
Tantalum	–	≤ 250 °C (482 °F)	≤ 250 °C (482 °F)
Pressure		Maximum 40 ... 100 bar (580.15 bar ... 1450.38 psi)	Maximum 700 bar (10152.64 psi)

NOTICE

The maximum temperatures and pressures specified are maximum values and do not take into consideration process-related stress. The effects of viscosity, medium velocity, pressure and temperature in the process usually cause these values to drop.

Overview of measuring insets TSA101

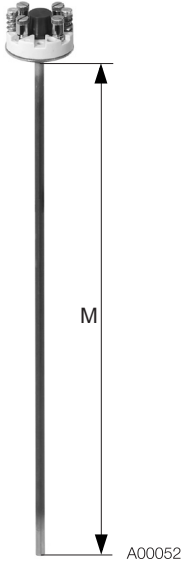
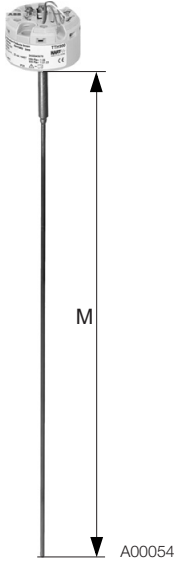
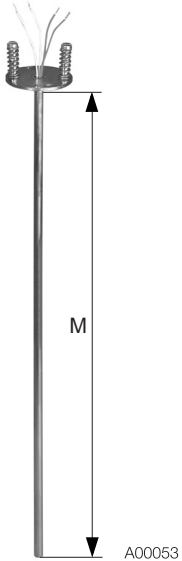
Industrial thermocouples and industrial resistance thermometers		
Ceramic base with connection terminals	Permanently-mounted transmitter	Open connection wires
		
<ul style="list-style-type: none"> – Flexible and vibration-resistant ABB mineral insulated cable. The sheath for the resistance thermometer is manufactured from CrNi steel 1.4571 (316Ti) or nickel-base alloy 2.4816 (alloy 600) for thermocouples. – Sensors in accordance with IEC 60751 platinum resistance thermometer with measuring ranges of -196 ... 800 °C (-320.8 ... 1472 °F) in three tolerance classes or thermocouples in accordance with IEC 60584 and ANSI MC96.1 with measuring ranges of -40 ... 1200 °C (-40 ... 2192 °F), each in two tolerance classes. – Type S thermocouple in an accuracy class of 0 ... 1600 °C (32 ... 2912 °F). – Fitted with single or double sensors. – Optimum clamping at the measuring inset's holding plate is assured by generous spring travel (10 mm (0.39 inch)) on the part of the clamping springs. – Measuring insets are available with outer diameters of 3 mm (0.12 inch), 4.5 mm (0.24 inch), 6 mm (0.24 inch), and for thermocouples also 8 mm (0.32 inch). 8 mm (0.32 inch) tip with sleeve and 10 mm (0.39 inch) tip with sleeve 		

M = Measuring inset length

Legend:

TSP311: $M = U + K + 40 \text{ mm}$

TSP321: $M = N + 40 \text{ mm}$

TSP331: $M = L + K + 40 \text{ mm}$

K = Extension tube length

U = Installation length

N = Nominal length

L = Thermowell length

SensyTemp TSP311, TSP321, TSP331 Temperature sensors

Installation instructions

The usual way of ensuring that thermal measurements are accurate is to comply with the minimum installation length of the temperature sensor. Ideally, in the case of pipelines, the sensor on a thermometer should be located in the center of the pipe. If this is not possible, both in the case of pipes and with containers, a minimum installation length of 10 to 15-times the thermowell diameter is assumed to be sufficient.

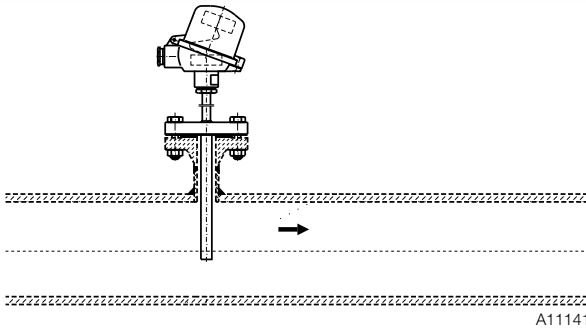

A11141

Fig. 1

Insufficient nominal diameter

In the case of pipelines with very small nominal diameters, insertion inside an elbow pipe is recommended. The thermowell tip is set in opposition to the flow direction of the medium. Inserting the thermowell with an adapter at an acute angle against the flow direction can also distort measurement results.

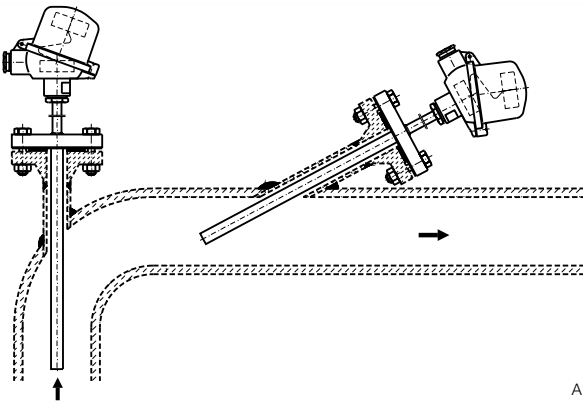

A11142

Fig. 2

Specifications

Resistance thermometer

The use of a mineral insulated cable and special installed measuring elements ensure very high vibration resistance of all measuring insets of the TSP temperature sensors.

The acceleration values of 30 m/sec² (3 g), defined for already increased requirements in accordance with the standard IEC 60751, are exceeded by all measuring inset types for TSP temperature sensors.

Apart from thin film resistors that reach their accuracy class within the temperature ranges defined by the standard IEC 60751, ABB also offers thin film resistors (TF) with extended temperature range. These TFs comply with the accuracy classes A and AA in a range of -196 ... 400 °C (-320.8 ... 752 °F) beyond the standard IEC 60751. These TFs are also available with increased resistance to vibration.

The optimally suitable combination of measuring range, diameter, accuracy, and vibration resistance can be taken from the following tables.

Designs

Basic design

Thin film resistor (TF)

	Measuring range	Vibration resistance
Class B	-50 ... 400 °C (-58 ... 752 °F)	100 m/sec ² (10 g) at 10 to 500 Hz
Class A	-30 ... 300 °C (-22 ... 572 °F)	
Class AA	0 ... 100 °C (32 ... 212 °F)	
Class A extended	-196 ... 400 °C (-321 ... 752 °F)	
Class AA extended	-196 ... 400 °C (-321 ... 752 °F)	

	Single sensor			Double sensor		
	2-W	3-W	4-W	2-W	3-W	4-W
3.0 mm, class B	●	●	●			
3.0 mm, class A		●	●			
3.0 mm, class AA		●	●			
4.5 mm, class B	●	●	●			
4.5 mm, class A		●	●			
4.5 mm, class AA		●	●			
6.0 mm, class B	●	●	●	●	●	●
6.0 mm, class A		●	●		●	●
6.0 mm, class AA		●	●		●	●

Increased vibration resistance

Thin film resistor (TF)

	Measuring range	Vibration resistance
Class B	-50 ... 400 °C (-58 ... 752 °F)	600 m/sec ² (60 g) at 10 to 500 Hz
Class A	-30 ... 300 °C (-22 ... 572 °F)	
Class AA	0 ... 100 °C (32 ... 212 °F)	
Class A extended	-196 ... 400 °C (-321 ... 752 °F)	
Class AA extended	-196 ... 400 °C (-321 ... 752 °F)	

	Single sensor			Double sensor		
	2-W	3-W	4-W	2-W	3-W	4-W
3.0 mm, class B	●	●	●			
3.0 mm, class A		●	●			
3.0 mm, class AA		●	●			
4.5 mm, class B	●	●	●			
4.5 mm, class A		●	●			
4.5 mm, class AA		●	●			
6.0 mm, class B	●	●	●	●	●	●
6.0 mm, class A		●	●		●	●
6.0 mm, class AA		●	●		●	●

Extended measuring range

Wire wound resistor (WW)

	Measuring range	Vibration resistance
Class B	-196 ... 800 °C (-320.8 ... 1472 °F)	100 m/sec ² (10 g) at 10 to 500 Hz
Class A	-100 ... 450 °C (-148 ... 842 °F)	

	Single sensor			Double sensor		
	2-W	3-W	4-W	2-W	3-W	4-W
3.0 mm, class B	●	●	●	●	●	
3.0 mm, class A		●	●		●	
4.5 mm, class B	●	●	●	●	●	
4.5 mm, class A		●	●		●	
6.0 mm, class B	●	●	●	●	●	●
6.0 mm, class A		●	●		●	●

Extended measuring range, increased vibration resistance

Wire wound resistor (WW)

	Measuring range	Vibration resistance
Class B	-196 ... 600 °C (-320.8 ... 1112 °F)	600 m/sec ² (60 g) at 10 to 500 Hz
Class A	-100 ... 450 °C (-148 ... 842 °F)	

	Single sensor			Double sensor		
	2-W	3-W	4-W	2-W	3-W	4-W
3.0 mm, class B						
3.0 mm, class A						
6.0 mm, class B	●	●	●	●	●	●
6.0 mm, class A		●	●		●	●

Length specifications for the tip of the measuring inset

The following table shows the minimum immersion length, the temperature-sensitive length and the non-flexible length at the tip of the measuring inset.

Version	Minimum immersion length	Temperature-sensitive length	Non-flexible length
Basic design	70 mm (2.75 inch)	7 mm (0.28 inch)	30 mm (1.18 inch)
Increased vibration resistance	70 mm (2.75 inch)	10 mm (0.39 inch)	40 mm (1.57 inch)
Extended measuring range, increased vibration resistance	70 mm (2.75 inch)	50 mm (1.97 inch)	60 mm (2.36 inch)

SensyTemp TSP311, TSP321, TSP331 Temperature sensors

Accuracy classes of measurement resistors in accordance with IEC 60751

Both thin film resistors and wire wound resistors in accordance with IEC 60751 can be used across the entire range of application (also with increased accuracy class AA or class A). Subsequently, only the accuracy class of the temperature range used can remain valid.

Example: A sensor of class AA is used at 290 °C. After the use (even short-term), Class A applies to this sensor, (example does not apply to the TFs of classes A extended and AA extended).

Thin film resistor (TF), built-in

Class B	$\Delta t = \pm (0.30 + 0.0050 \times [t])$	-50 ... 400 °C (58 ... 752 °F)
Class A	$\Delta t = \pm (0.15 + 0.0020 \times [t])$	-30 ... 300 °C (-22 ... 572 °F)
Class AA	$\Delta t = \pm (0.10 + 0.0017 \times [t])$	0 ... 100 °C (32 ... 212 °F)
Class A extended	$\Delta t = \pm (0.15 + 0.0020 \times [t])$	-196 ... 400 °C (-320.8 ... 752 °F)
Class AA extended	$\Delta t = \pm (0.10 + 0.0017 \times [t])$	-196 ... 400 °C (-320.8 ... 752 °F)

Wire wound resistor (WW), built-in

Class B	$\Delta t = \pm (0.30 + 0.0050 \times [t])$	-196 ... 600 °C (-320.8 ... 1112 °F)
Class A	$\Delta t = \pm (0.15 + 0.0020 \times [t])$	-100 ... 450 °C (-148 ... 842 °F)

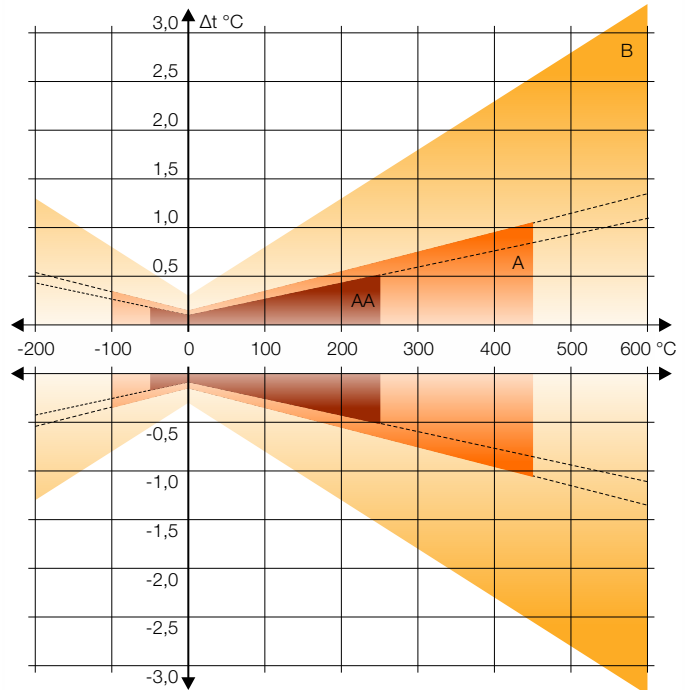

A11228

Fig. 3: Graphical presentation of the accuracy classes

Colored areas: Temperature range in accordance with IEC 60751 (WW)

Dashed line: Extended temperature range

Measuring errors with two-wire circuits

The electrical resistance of the copper inner conductor for the measuring inset affects the measured value for two-wire circuits and must be taken into consideration. It depends on the diameter and length of the measuring inset.

If the error cannot be compensated metrologically, the following reference values shall apply:

- Measuring inset Ø 3.0 mm: $(0.281 \Omega/m \Rightarrow 0.7 \text{ °C/m})$
- Measuring inset Ø 6.0 mm: $(0.1 \Omega/m \Rightarrow .25 \text{ °C/m})$

It is for this reason that ABB supplies three-wire / four-wire circuits as standard.

Thermocouples

The accuracy classes of the thermocouples meet the requirements of the international standard IEC 60584. On request, ABB can also supply thermocouples in accordance with ANSI MC96.1 and DIN 43710.

Since the values of both standards differ from each other only very slightly at low temperatures (up to approx. 300 °C(572 °F)), ABB recommends using thermocouples in accordance with IEC 60584. The tolerance specifications are presented in the table "Accuracy classes in accordance with IEC 60584".

The following table shows the temperature-sensitive length, the minimum immersion length, and the non-flexible length at the tip of the temperature sensor.

Version	Minimum immersion length	Temperature-sensitive length	Non-flexible length
Vibration-resistant up to 600 m/sec ² (60 g)	70 mm (2.76 inch)	7 mm (0.28 inch)	30 mm (1.18 inch)

	1K	2K	3K	1J	2J	1L ¹⁾	2L ¹⁾	1N	2N	1T	2T	1E	2E	1S	2S
3.0 mm, class 2	•	•		•	•	•	•	•	•						
3.0 mm, class 1	•	•		•	•			•	•						
4.5 mm, class 2	•	•													
4.5 mm, class 1	•	•													
6.0 mm, class 2	•	•	•	•	•	•	•	•	•	•	•	•	•	•	•
6.0 mm, class 1	•	•		•	•			•	•	•	•	•	•		

1) Tolerance in accordance with DIN 43710

Accuracy classes in accordance with IEC 60584, DIN 43710 and ANSI MC96.1

IEC 60584	Class (CL)	Temperature range	Maximum measuring error
K (NiCr-Ni), N (NiCrSi-NiSi)	2	-40 ... 333 °C (-40 ... 631.4 °F)	±2.5 °C (36.5 °F)
		333 ... 1200 °C (631.4 ... 2192 °F)	±0.0075 x [t]
	1	-40 ... 375 °C (-40 ... 707 °F)	±1.5 °C (34.7 °F)
		375 ... 1000 °C (707 ... 1832 °F)	±0.004 x [t]
J (Fe-CuNi)	2	-40 ... 333 °C (-40 ... 631.4 °F)	±2.5 °C (36.5 °F)
		333 ... 750 °C (631.4 ... 1382 °F)	±0.0075 x [t]
	1	-40 ... 375 °C (-40 ... 707 °F)	±1.5 °C (34.7 °F)
		375 ... 750 °C (707 ... 1382 °F)	±0.004 x [t]
T (Cu-CuNi)	2	-40 ... 133 °C (-40 ... 271.4 °F)	±1.0 °C (33.8 °F)
		133 ... 350 °C (271.4 ... 662 °F)	±0.0075 x [t]
	1	-40 ... 125 °C (-40 ... 257 °F)	±0.5 °C (32.9 °F)
		125 ... 350 °C (257 ... 662 °F)	±0.005 x [t]
S (Pt10%Rh-Pt)	2	0 ... 600 °C (32 ... 1112 °F)	±1.5 °C (34.7 °F)
		600 ... 1600 °C (1112 ... 2912 °F)	±0.0025 x [t]
E (NiCr-CuNi)	2	-40 ... 333 °C (-40 ... 631.4 °F)	±2.5 °C (36.5 °F)
		333 ... 900 °C (631.4 ... 1652 °F)	±0.0075 x [t]
	1	-40 ... 375 °C (-40 ... 707 °F)	±1.5 °C (34.7 °F)
		375 ... 800 °C (707 ... 1472 °F)	±0.004 x [t]

SensyTemp TSP311, TSP321, TSP331 Temperature sensors

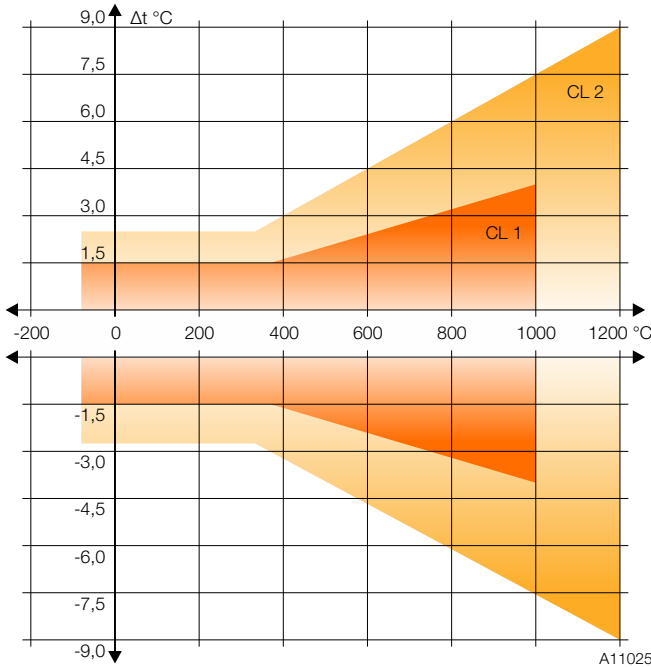

Fig. 4: Graphical representation of the accuracy classes using type K and N as examples in accordance with IEC 60584. See tables for other types.

DIN 43710	Temperature range	Maximum measuring error
L (Fe-CuNi)	50 ... 400 °C (122 ... 752 °F)	±3.0 °C (37.4 °F)
	400 ... 900 °C (752 ... 1652 °F)	±0.0075 x [t]

ANSI MC 96.1	Class (CL)	Temperature range	Maximum measuring error
K (NiCr-Ni), N (NiCrSi-NiSi)	Standard	0 ... 293 °C (32 ... 559.4 °F)	±2.2 °C (35.96 °F)
		293 ... 1250 °C (559.4 ... 2282 °F)	±0.0075 x [t]
	Special	0 ... 275 °C (32 ... 527 °F)	±1.1 °C (33.98 °F)
		275 ... 1250 °C (527 ... 2282 °F)	±0.0040 x [t]
J (Fe-CuNi)	Standard	0 ... 293 °C (32 ... 559.4 °F)	±2.2 °C (35.96 °F)
		293 ... 750 °C (559.4 ... 1382 °F)	±0.0075 x [t]
	Special	0 ... 275 °C (32 ... 527 °F)	±1.1 °C (33.98 °F)
		275 ... 750 °C (527 ... 1382 °F)	±0.0040 x [t]
N (NiCrSi-NiSi)	Standard	0 ... 293 °C (32 ... 559.4 °F)	±2.2 °C (35.96 °F)
		293 ... 1250 °C (559.4 ... 2282 °F)	±0.0075 x [t]
	Special	0 ... 275 °C (32 ... 527 °F)	±1.1 °C (33.98 °F)
		275 ... 1250 °C (527 ... 2282 °F)	±0.0040 x [t]

Insulation resistance of measuring inset

The insulation resistance is measured between the outer sheath and measuring circuit. If there are two measuring loops, the insulation resistance between both measuring loops is also measured.

The following applies for all measuring inset types:

- 500 V DC
- Insulation resistance $R_{iso} \geq 500M\Omega$ with an ambient temperature range of 15 ... 35 °C (59 ... 95 °F)
- Humidity < 80 %.

Thanks to a special process used during manufacturing, ABB measuring insets can boast outstanding insulation values even at high temperatures.

Thermowells

Thermowell functions

- Protection against aggressive media, high process pressures, and high flow rates
- Replacement or recalibration of the measuring unit without interrupting the process

Depending on the medium, temperature and process pressure, several different designs and materials are available.

The thermowells are divided into two categories:

- Welded protective fittings manufactured from pipe material for TSPX21
- Drilled thermowells manufactured from bar stock material for TSPX31

Available in accordance with DIN 43772 or ABB standard.

Use in highly aggressive media

- A special coating of PFA or ECTFE with a standard coat thickness of 0.5 mm (0.02 inch) can be applied for the corresponding usage.

Use in highly corrosive applications

- For thermowells with flange, a tantalum sheath can be applied for the corresponding usage.

If required, contact your ABB partner.

Response times in accordance with IEC 60751 and IEC 60584

The thermowell used in each application and the thermal contact between thermowell and measuring inset have an impact on the response times of TSP temperature sensors. In the case of TSPX21 and TSPX31 temperature sensors, the design of the thermowell tip has been adapted to the measuring inset. This maximizes heat transmission. The following table shows typical response times for the SensyTemp TSP series, measured in accordance with IEC 60751 in water with 0.4 m/s and a temperature rise from 25 °C (77 °F) to 35 °C (95 °F).

Thermowell form	Diameter [mm]	In water 0.4 m/s	
		t _{0,5}	t _{0,9}
Resistance thermometer			
2, 2G, 2F, 2G0	9 x 1	25	77
	11 x 2	23	64
3, 3G, 3F	12 / 9 mm tip	15	38
2S, 2GS, 2FS, 2GS0	12 / 6 mm tip	21	55
Thermocouples			
2, 2G, 2F, 2G0	9	10	24
	11	12	28
3, 3G, 3F	12 / 9 mm tip	12	24
2S, 2GS, 2FS, 2GS0	12 / 6 mm tip	6	14
	14 / 6 mm tip	6	14

SensyTemp TSP311, TSP321, TSP331 Temperature sensors

Welded thermowells (TSP321)

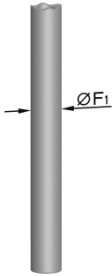
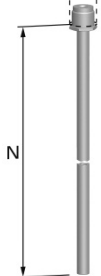
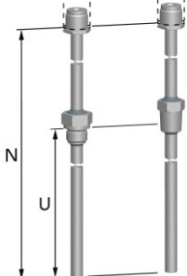
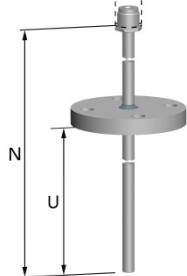
Straight shaft	DIN 43772 – form 2	DIN 43772 – form 2G	DIN 43772 – form 2F
M24 x 1.5 head connection			
			
1.4571/316Ti	F1 = 12, 14 mm	F1 = 9, 11, 12, 14 mm	F1 = 11, 12, 14 mm
1.4404/316L	F1 = 12, 14 mm	F1 = 12, 14 mm	F1 = 12, 14 mm
2.4819/C-276	–	F1 = 13.7 mm ¹⁾	F1 = 13.7 mm ¹⁾
Measuring inset	Ø 6 mm	Ø 6 mm	Ø 6 mm

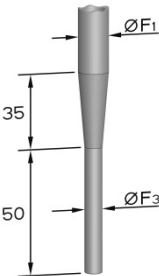
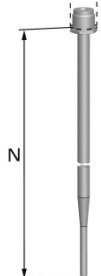
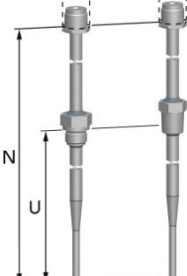
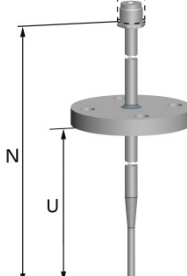
Tapered tip	DIN 43772 – form 3	DIN 43772 – form 3G	DIN 43772 – form 3F
M24 x 1.5 head connection			
			
1.4571/316Ti	F1/F3 = 12/9, 16/10 mm	F1/F3 = 12/9 mm	F1/F3 = 12/9, 16/10 mm
1.4404/316L	F1/F3 = 12/9 mm	F1/F3 = 12/9 mm	F1/F3 = 12/9 mm
Measuring inset	Ø 6 mm	Ø 6 mm	Ø 6 mm

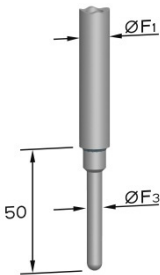
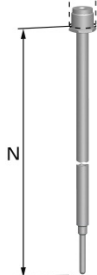
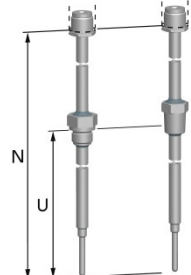
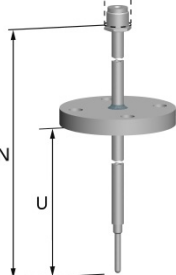
Stepped tip	ABB – form 2S	ABB – form 2GS	ABB – form 2FS
M24 x 1.5 head connection			
			
1.4571/316Ti	F1/F3 = 12/6, 14/6 mm	F1/F3 = 11/6, 12/6, 14/6 mm	F1/F3 = 11/6, 12/6, 14/6 mm
1.4404/316L	F1/F3 = 12/6, 14/6 mm	F1/F3 = 12/6, 14/6 mm	F1/F3 = 12/6, 14/6 mm
2.4819/C-276	—	F1/F3 = 13.7/6 mm ¹⁾	F1/F3 = 13.7/6 mm ²⁾
Measuring inset	Ø 3 mm	Ø 3 mm	Ø 3 mm

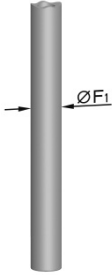
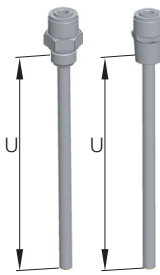
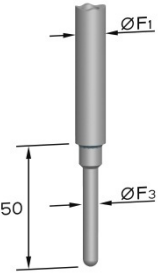
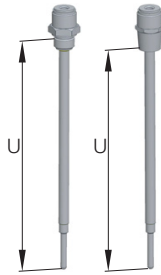
Straight shaft without extension tube	ABB – form 2G0	Stepped tip without extension tube	ABB – form 2GS0
M24 x 1.5 head connection		M24 x 1.5 head connection	
			
1.4571/316Ti	F1 = 9, 11, 12 mm ¹⁾	1.4571/316Ti	F1/F3 = 11/6, 12/6 mm ¹⁾
Measuring inset	Ø 6 mm	Measuring inset	Ø 3 mm

1) Only with G1/2A, 1/2" NPT thread
2) Flange 1.4571/316Ti, flange disc 2.4819/C-276

Other diameters and materials available on request.

SensyTemp TSP311, TSP321, TSP331

Temperature sensors

Drilled thermowells (TSP331)

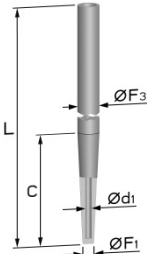
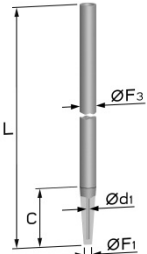
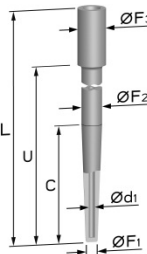
Weld-in thermowell		DIN 43772 – form 4		DIN 43772 – form 4		ABB – form PW	
Extension tube connection		M18 x 1.5		M14 x 1.5		1/2" NPT	
							
Material		1.4404/316L; 1.4571/316Ti; 1.7335/13CrMo4-5; 1.5415/15Mo3				1.4404/316L; 1.4571/316Ti 1.4876/Incoloy 800; 2.4360/Monel 400 2.4816/Inconel 600; 2.4819/C-276	
F3/F2/F1	d1	24h7/12.5 mm	7 mm	18h7/9 mm	3.5 mm	32/23/13.5 mm	7 mm
Measuring inset		Ø 6 mm		Ø 3 mm		Ø 6 mm	

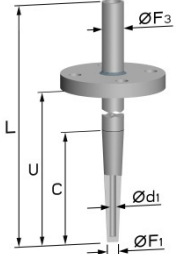
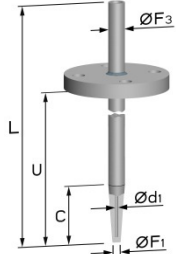
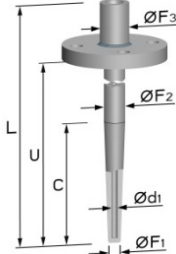
Flange thermowell		DIN 43772 – form 4F		DIN 43772 – form 4FS		ABB – form PF	
Extension tube connection		M18 x 1.5		M14 x 1.5		1/2" NPT	
							
Material		1.4404/316L; 1.4571/316Ti		1.4404/316L; 1.4571/316Ti		1.4404/316L; 1.4571/316Ti 1.4876/Incoloy 800; 2.4360/Monel 400 ¹⁾ 2.4816/Inconel 600; 2.4819/C-276 ¹⁾	
F3/F2/F1	d1	24/12.5 mm	7 mm	18/9 mm	3.5 mm	32/23/13.5 mm	7 mm
Measuring inset		Ø 6 mm		Ø 3 mm		Ø 6 mm	

1) 1.4876/Incoloy 800; 2.4360/Monel 400; 2.4816/Inconel 600; 2.4819/C-276 with flange in 1.4571/316Ti and flange disc

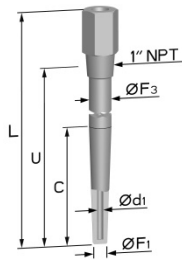
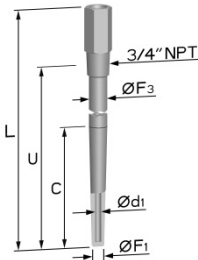
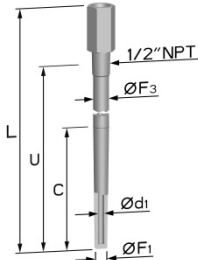
Screw-in thermowell		ABB – form PS		ABB – form PS		ABB – form PS	
Extension tube connection		1/2" NPT; WAF 36		1/2" NPT; WAF 27		1/2" NPT; WAF 27	
							
Material		1.4404/316L; 1.4571/316Ti; 1.4876/Incoloy 800; 2.4360/Monel 400; 2.4816/Inconel 600; 2.4819/C-276					
F3/F1	d1	25/16 mm	7 mm	20/13.5 mm	7 mm	17/13.5 mm	7 mm
Measuring inset		Ø 6 mm		Ø 6 mm		Ø 6 mm	

Other diameters and materials available on request.

Standard lengths

Welded thermowells mm (inch)		
Form	N = 230 (9.055)	U = 100 (3.94)
2; 2G; 2F;	N = 290 (11.42)	U = 160 (6.30)
3; 3G; 3F;	N = 380 (14.96)	U = 250 (9.84)
2S; 2GS; 2FS	N = 530 (20.87)	U = 400 (15.75)
Drilled thermowells mm (inch)		
Form 4	L = 140 (5.51)	C = 65 (2.56)
	L = 200 (7.87)	C = 65 (2.56)
	L = 200 (7.87)	C = 125 (4.92)
	L = 260 (10.24)	C = 125 (4.92)
	L = 410 (16.14)	C = 275 (10.83)
Form 4S	L = 110 (4.33)	C = 65 (2.65)
	L = 140 (5.51)	C = 65 (2.65)
Form PW; PF; PS	U = 100 (3.94), 150 (5.91), 200 (7.87), 250 (9.84), 300 (11.81), 350 (13.78)	L = U + 65 (2.56)
Form 4F	U = 130 (5.12), L = 200 (7.87)	C = 65 (2.56)
	U = 190 (7.48), L = 260 (10.24)	C = 125 (4.92)
	U = 340 (13.39), L = 410 (16.14)	C = 275 (10.83)
Form 4FS	U = 130 (5.12), L = 200 (7.87)	C = 65 (2.65)

SensyTemp TSP311, TSP321, TSP331 Temperature sensors

Pressure and vibration resistance of thermowell

The permissible compressive loads for thermowells at various temperatures are illustrated in the following figures (thermowells conforming to DIN 43772).

The curves can also be applied to identical thermowell models.

Thermowell form 2 (material 1.4571)

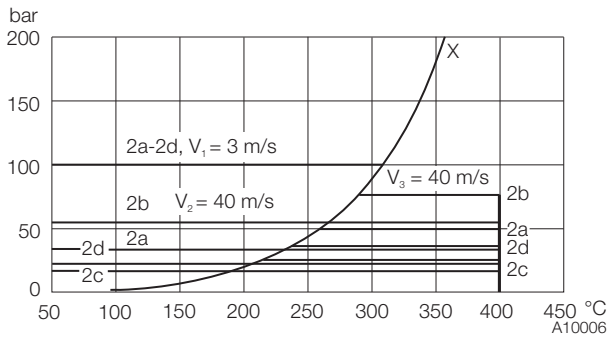

Fig. 5

- X Vapor-pressure curve
- V_1 Flow rate in water
- V_2 Flow rate in air
- V_3 Flow rate in steam

Curve	Installation length (mm)	Thermowell diameter (mm)
2a	250	11
2b	250	14
2c	400	11
2d	400	14

Thermowell form 3 (material 1.4571)

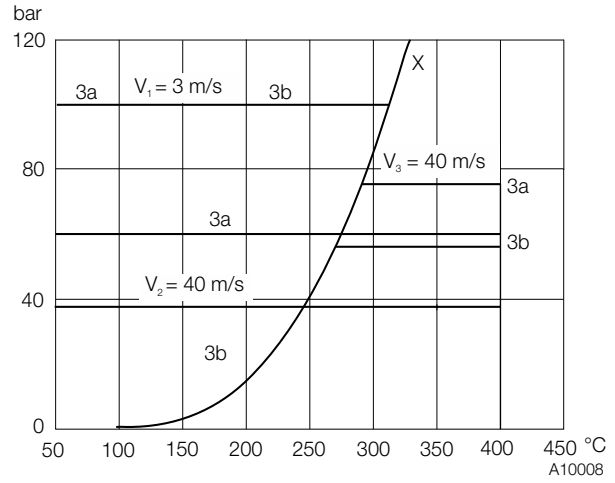

Fig. 6

- X Vapor-pressure curve
- V_1 Flow rate in water
- V_2 Flow rate in air
- V_3 Flow rate in steam

Curve	Installation length (mm)	Thermowell diameter (mm)
3a	225	12/9
3b	285	12/9

Thermowell form 4 (material 1.4571)

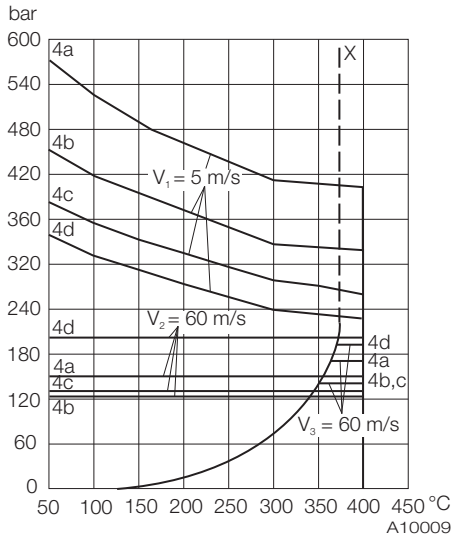

Fig. 7

- X Vapor-pressure curve
- V_1 Flow rate in water
- V_2 Flow rate in air
- V_3 Flow rate in steam

Curve	Installation length (mm)	Thermowell diameter (mm)
4a	65	18
4b	125	24
4c	125	26
4d	125	32

NOTICE

The diagrams above have been taken from DIN 43772. They are based on the Dittrich calculation model. They do not take possible vibration caused by vortex excitation of the flowing medium into account.

ABB's standard thermowells are sufficiently robust for most industrial applications provided that design, material, and length are properly selected.

Most thermowell failures are caused by flow-related vibration. For this reason, ABB offers a stress analysis for ABB thermowells, based on the respective usage parameters.

Thermowell form 4 (material 1.7335 and 1.7380)

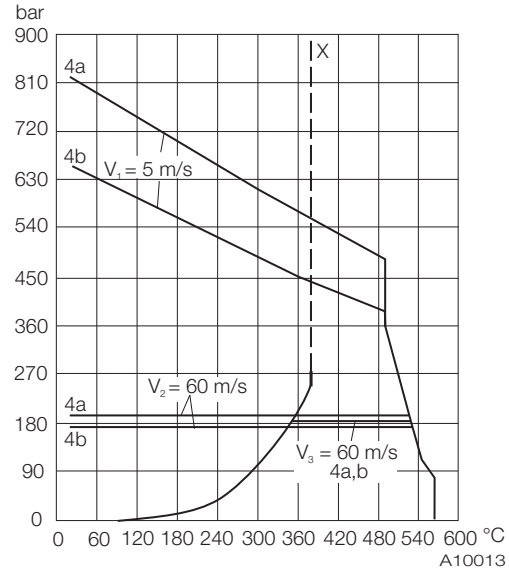

Fig. 8

- X Vapor-pressure curve
- V_1 Flow rate in water
- V_2 Flow rate in air
- V_3 Flow rate in steam

Curve	Installation length (mm)	Thermowell diameter (mm)
4a	65	18
4b	125	24

The stress analysis conforms to ASME PTC 19.3-2010. It is based on recognized theoretical methods and is intended to support thermowell selection for critical applications. It is not, however, a guarantee against failure of the thermowell.

Given the relatively unreliable computational estimation of the natural frequency of a thermowell and taking the numerous influencing factors into account, experimental testing is recommended in critical cases.

For more detailed information about thermowell loads and calculation methods, please see DIN 43772.

SensyTemp TSP311, TSP321, TSP331

Temperature sensors

Process connections

SensyTemp TSP321 temperature sensor

Plug-in thermowells, welded	Sliding connection
DIN 43772 – form 2, straight shaft	G1/2"A, 1/2" NPT
DIN 43772 – form 3, tapered tip	
ABB – form 2S, stepped tip	

NOTICE

All ABB compression fittings are manufactured from CrNi-steel and are supplied without material certification in accordance with EN 10204.

Screw-in thermowells, welded	Fixed connection
DIN 43772 – form 2G, straight shaft	G3/8"A, G1/2"A, G3/4"A, G1"A, 1/2" NPT, 3/4" NPT, 1" NPT M20 x 1,5, M27 x 2, 1/2" BSPT, 3/4" BSPT, 1" BSPT
DIN 43772 – form 3G, tapered tip	
ABB – form 2GS, stepped tip	
ABB – form 2G0, without extension tube	
ABB – form 2GS0, without extension tube Stepped tip	

Flange thermowells, welded	Flange in accordance with EN 1092-1 Sealing surface form B1/B2 ¹⁾	Flange in accordance with ASME B16.5 TW Sealing surface form RF ¹⁾	Tri-clamp flange BS4825
DIN 43772 – form 2F, straight shaft	DN 15, PN 10 ... PN 40 DN 20, PN 10 ... PN 40 DN 25, PN 10 ... PN 40, PN 63 ... PN 100 DN 32, PN 16 ... PN 40, PN 63 ... PN 100 DN 40, PN 10 ... PN 40, PN 63 ... PN 100 DN 50, PN 6, PN 10 ... PN 40, PN 63 ... PN 100 DN 80, PN 16 DN 100, PN 40	Nominal diameter 1", Nominal pressure 150, 300, 600 lbs. Nominal diameter 1 1/2", nominal pressure 150, 300, 600, 900/1500 lbs. Nominal diameter 2", nominal pressure 150, 300, 600, 900/1500 lbs.	On request
DIN 43772 – form 3F, tapered tip			
ABB – form 2FS, stepped tip			

1) Others available on request

SensyTemp TSP331 temperature sensor

Weld-in thermowells, drilled			
Weld-in thermowells are available as DIN 43772 form 4 and ABB form PW. Other forms are available on request.			
Screw-in thermowells, drilled	Screw-in thread		
DIN 43772 – form 6 and ABB form PS	G1/2"A, 1/2" NPT, 3/4" NPT, 1" NPT, M20 x 1.5		
Flange thermowells, drilled	Flange in accordance with EN 1092-1	Flange in accordance with ASME B16.5 TW	Tri-clamp flange BS4825
	Sealing surface form B1/B2 ¹⁾	Sealing surface form RF ¹⁾	
DIN 43772 – form 4F, F2 = 18 mm, 24 mm, 26 mm, thermowell manufactured from bar stock material	DN 25, PN 10 ... PN 40, PN 63 ... PN 100 DN 32, PN 16 ... PN 40 DN 40, PN 10 ... PN 40, PN 63 ... PN 100	Nominal diameter 1", nominal pressure 150, 300, 600 lbs.	On request
ABB – form PF, thermowell manufactured from bar stock material	DN 50, PN 6, PN 10 ... PN 40, PN 63 ... PN 100 DN 80, PN 16 DN 100, PN 40	Nominal diameter 1 1/2", nominal pressure 150, 300, 600, 900 / 1500 lbs. Nominal diameter 2", nominal pressure 150, 300, 600, 900/1500 lbs.	

1) Others available on request

NOTICE

Other process connections are available on request. If required, contact your ABB partner.

SensyTemp TSP311, TSP321, TSP331 Temperature sensors

Extension tubes

The extension tube is the component between thermowell and connection head. It is used to bridge any existing insulation or serves as a cooling section between the temperature-sensitive electronics of the transmitter in the connection head and the process.

The relation illustrated in Fig. 9 led to the selection of the standard extension tube with length $K = 130 \text{ mm}$ (5.12 inch). If the two threads are manufactured in one part (known as a double nipple), a minimum length of $K = 25 \text{ mm}$ (0.98 inch) is possible.

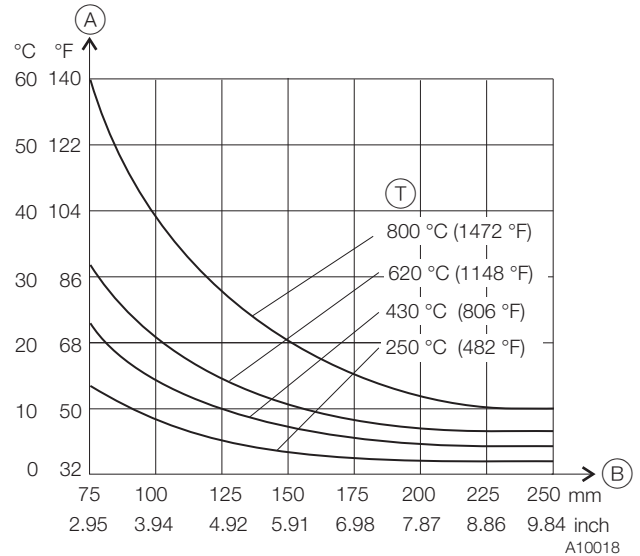



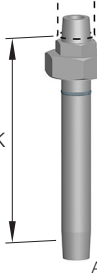
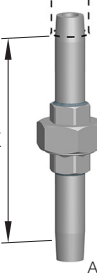

Fig. 9

(A) Overtemperature at the connection head compared to the ambient temperature (B) Extension tube length (T) Flange temperature

Extension tube models

	Cylindrical screw-in thread	Conical screw-in thread	1/2" NPT - 1/2" NPT, not separable (nipple)	1/2" NPT - 1/2" NPT, separable (nipple-union)	1/2" NPT - 1/2" NPT, separable (nipple-union-nipple)
Head connection	M24 x 1.5		1/2" NPT		
 A11156	 A11056	 A11057	 A11151	 A11058	 A11059
Thermowell connection	G3/8", G1/2" M14 x 1,5; M18 x 1,5; M20 x 1,5;		1/2" NPT		
Material	1.4571/316Ti				

Connection heads

Functions of the connection head

- Housing for a transmitter or coupler connector
- Protection of the connection area against adverse environmental effects

When the connection cable is fed into the connection head, a special cable guide system automatically positions it inside the connection area. The flat base of the housing ensures optimum access to the connection area. A second cable entry is available as an option.

Ambient temperature at connection head

Connection head without transmitter and without cable gland	-40 ... 120 °C (-40 ... 248 °F)
Connection head with transmitter	-40 ... 85 °C (-40 ... 185 °F)
Connection head with LCD indicator	-20 ... 70 °C (-4 ... 158 °F)

i NOTICE

In case of using in explosive environments, restrictions of the ambient temperature range are possible. The notes of the corresponding declarations of conformity and type examination certificate are to be followed.

The cable gland made of plastic used by default for cable outer diameter of 5.5 ... 13 mm (0.22 ... 0.51 inch) is suitable for a temperature range of -40 ... 70 °C (-40 ... 158 °F). For temperatures outside this range, an appropriate cable gland can be installed.

The metal cable gland used for Ex-d (flameproof enclosure) by default for cable outer diameter of 3.2 ... 8.7 mm (0.13 ... 0.34 inch) covers the temperature range of -40 ... 120 °C (-40 ... 248 °F).

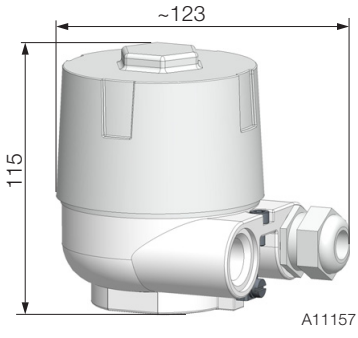
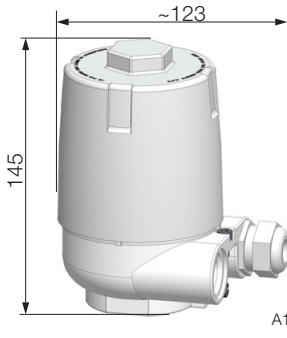
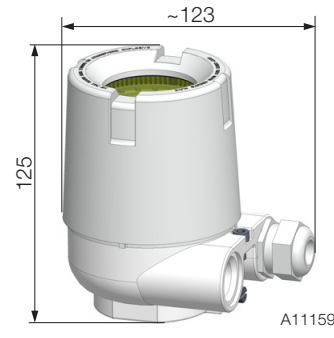
Head form	AGL / AGS	AGLH / AGSH	AGLD / AGSD
	 <p style="text-align: right;">A11157</p>	 <p style="text-align: right;">A11158</p>	 <p style="text-align: right;">A11159</p>
Material	AGL: Aluminum, epoxy-coated AGS: Stainless steel	AGLH: Aluminum, epoxy-coated AGS: Stainless steel	AGLH: Aluminum, epoxy-coated AGS: Stainless steel
Cover locking system	Screw-on cap		
Cable gland	M20 x 1.5, optional cable entry 1/2" NPTF, without cable gland		
IP rating	IP 66 / IP67		
Transmitter mounting	On the measuring inset	On the mounting bracket (mounting on the measuring inset available as an option)	On the measuring inset

Dimensions in mm

SensyTemp TSP311, TSP321, TSP331 Temperature sensors





Transmitter

Installing a transmitter has the following advantages:

- Decreased cost due to reduced wiring.
- Amplification of the sensor signal at the measuring point and conversion to a standard signal (thereby increasing the signal's interference immunity).
- Option to install an LCD indicator in the connection head.
- SIL2 with accordingly classified transmitter.

The output signal of a temperature sensor is determined by the selection of the corresponding transmitter. When using ABB transmitters, self-heating can be ignored.

The following output signals are available:

Type	
TTH200 HART 4 ... 20 mA, HART	 A11232
TTH300 HART 4 ... 20 mA, HART	 A11233
TTH300 PA PROFIBUS PA	 A11234
TTH300 FF FOUNDATION Fieldbus H1	 A11235

NOTICE

Further information on the transmitters listed above can be found in the data sheets DS/TTH200 and DS/TTH300.

Type A and type AS LCD indicator

AGLD and AGSD connection heads are fitted with a digital LCD indicator. A suitable transmitter is connected via an add-on interface cable.

We recommend using an LC display with type AS display function if you are using a TTH200. If the TTH300 transmitter is selected, the type A LCD indicator can also be used to configure the transmitter.



A10242

Fig. 10: (A) LCD indicator type A (B) LCD indicator type AS
① Exit / Cancel ② Scroll back ③ Scroll forwards ④ Select

Functional safety (SIL)

SensyTemp TSP temperature sensors with SIL certified transmitters fitted ex works are available with conformity in accordance with IEC 61508 for use in safety-related applications up to SIL 3 (redundant). When using a transmitter, the device fulfills the requirements in accordance with SIL 2. When using two redundant transmitters, the device fulfills the requirements in accordance with SIL 3.

Information regarding functional safety for SensyTemp TSP temperature sensors can be found in the SIL safety instructions.

Information about temperature sensors without built-in electronics can be found in the operating instruction.

Use in potentially explosive atmospheres in accordance with ATEX

Approvals

TSP3X1 temperature sensors hold numerous approvals.

These range from metrological approvals through Ex approvals for individual countries, ATEX certificates applicable across EU and in Switzerland up to internationally recognized IECEx documents.

Specifically, these are:

- ATEX Ex i PTB 01 ATEX 2200 X
- ATEX dust ignition protection BVS 06 ATEX E 029
- ATEX Ex d PTB 99 ATEX 1144
- Ex n (Zone 2 and 22) Declarations of conformity
- IECEx
- GOST / EAC Ex

Conditions for the use in potentially explosive areas

The operator assumes responsibility for the proper installation according to the valid approval conditions when replacing the measuring inset in a thermometer. It is necessary to specify the production no. marked on the old part to ABB, so that ABB can examine the conformity of the ordered execution with the first delivery and the applicable approval.

Thermal resistance

The following table lists thermal resistances for measuring insets in diameter < 6.0 mm (0.24 inch) and ≥ 6.0 mm (0.24 inch). The values have been specified subject to the conditions "Gas with a flow velocity of 0 m/s" and "Measuring inset without or with an additional thermowell".

Thermal resistance R_{th} $\Delta t = 200 \text{ K/W} \times 0.038 \text{ W} = 7.6 \text{ K}$	Measuring inset $\varnothing < 6 \text{ mm}$ (0.24 inch)	Measuring inset $\varnothing \geq 6 \text{ mm}$ (0.24 inch)
Without thermowell		
Resistance thermometer	200 K/W	84 K/W
Thermocouple	30 K/W	30 K/W
With thermowell		
Resistance thermometer	70 K/W	40 K/W
Thermocouple	30 K/W	30 K/W

K/W = kelvin per watt

Temperature rise in the event of a fault

In the event of a fault, the temperature sensors will exhibit a temperature rise Δt as appropriate for the applied power. This Δt temperature rise must be taken into account with regard to the difference between process temperature and temperature class.

NOTICE

In the event of a fault (short-circuit), the dynamic short-circuit current that occurs in the measurement circuit for a matter of milliseconds is not relevant with regard to temperature rise.

The Δt temperature rise can be calculated using the following formula: $\Delta t = R_{th} \times P_o$ [K/W x W]

- Δt = Temperature rise
- R_{th} = Thermal resistance
- P_o = Output power of an additional connected transmitter

Example:

Resistance thermometer diameter 3 mm (0.12 inch) without thermowell:

$$R_{th} = 200 \text{ K/W,}$$

Temperature transmitter TTHXXX $P_o = 38 \text{ mW}$, see also "Output power P_o for transmitters of ABB" on page 22.

$$\Delta t = 200 \text{ K/W} \times 0.038 \text{ W} = 7.6 \text{ K}$$

Therefore, at transmitter output power $P_o = 38 \text{ mW}$, the temperature rise in the event of a fault is approximately 8 K. This results in the following maximum possible process temperatures T_{medium} , as shown in the table "Maximum process temperature T_{medium} in Zone 0:" on page 22 .

SensyTemp TSP311, TSP321, TSP331

Temperature sensors

Intrinsic safety ATEX "Ex i"

Suitable thermowells in accordance with PTB 01 ATEX 2200 X are to be used.

In the area of the electrical connections, the permissible ambient temperature range is -40 ... 80 °C (-40 ... 176 °F).

Electrical power limit Ex i

All of the values listed below are valid assuming that an additional transmitter has been connected. The following electrical values must not be exceeded:

U_i (input voltage)	I_i (input current)
30 V	101 mA
25 V	158 mA
20 V	309 mA

P_i (internal power) = max. 0.5 W

Note: The internal power P_i corresponds to the output power P_o of the connected transmitter.

L_i (internal inductance) = 15 μ H/m

C_i (internal capacitance) = 280 pF/m

Output power P_o for transmitters of ABB

Transmitter type	P_o
TTH200 HART	≤ 38 mW
TTH300 HART	≤ 38 mW
TTH300 PA	≤ 38 mW
TTH300 FF	≤ 38 mW

All other information required to prove intrinsic safety (U_o , I_o , P_o , L_o , C_o etc.) can be taken from the type examination certificates for the relevant transmitter models.

Maximum process temperature T_{medium} in Zone 0:

The surface temperature of Category 1 devices must not exceed 80 % of the ignition temperature of a flammable gas or liquid. For the temperature T_{medium} , the temperature increase of 8 K in case of fault calculated as an example in chapter "Conditions for the use in potentially explosive areas" on page 21 is considered here.

Temperature class	80 % of the ignition temperature	T_{medium}
T1 (450 °C (842 °F))	360 °C (680 °F)	352 °C (665.5 °F)
T2 (300 °C (572 °F))	240 °C (464 °F)	232 °C (449.6 °F)
T3 (200 °C (392 °F))	160 °C (320 °F)	152 °C (305.6 °F)
T4 (135 °C (275 °F))	108 °C (226.4 °F)	100 °C (212 °F)
T5 (100 °C (212 °F))	80 °C (176 °F)	72 °C (161.6 °F)
T6 (85 °C (185 °F))	68 °C (154.4 °F)	60 °C (140 °F)

Maximum process temperature T_{medium} in Zone 1:

To calculate the temperature classes for T3, T4, T5 and T6, 5 K in each instance must be deducted; for T1 and T2, 10 K in each instance must be deducted.

Temperature class	-5 K	-10 K	T_{medium}
T1 (450 °C (842 °F))	-	440 °C (824 °F)	432 °C (809.6 °F)
T2 (300 °C (572 °F))	-	290 °C (554 °F)	282 °C (539.6 °F)
T3 (200 °C (392 °F))	195 °C (383 °F)	-	187 °C (368.6 °F)
T4 (135 °C (275 °F))	130 °C (266 °F)	-	122 °C (251.6 °F)
T5 (100 °C (212 °F))	95 °C (203 °F)	-	87 °C (188.6 °F)
T6 (85 °C (185 °F))	80 °C (176 °F)	-	72 °C (161.6 °F)

**Flameproof enclosure "Ex d"
(only TSP3X1)**

The enclosures for thermometers of this design are flameproof. An explosion inside the thermometer will not ignite the explosive atmosphere in the area in which the device is located. Alongside the use of a flameproof enclosure, this is achieved by compliance with specified ignition gap lengths and widths (between enclosure and measuring inset) and "Ex d" certified cable entries.

SensyTemp TSP300 temperature sensors can be used as "Ex d" versions in the following zones provided that the corresponding requirements are met:

- With suitable thermowell and connection head in Zone 1 / 0 (zone separation, thus measuring inset in Zone 0).
- With connection head but without thermowell, in Zone 1

These thermometers hold type examination certificate PTB 99 ATEX 1144 with Ex marking II 1/2 G Ex d IIC T1-T6 Ga/Gb. The connection conditions listed there are to be complied with.

The self-heating of the sensor, in accordance with the chapter "Thermal resistance" on page 21 must be taken into consideration when connecting to transmitters and supply isolators that are not intrinsically safe.

The temperature class and the maximum permissible temperature of the measuring medium must be determined accordingly.

Temperature ranges:

Maximum permissible ambient temperature: -40 ... 60 °C (-40 ... 140 °F)

Maximum permissible temperature in connection head:

Temperature class	Without transmitter	With transmitter
T1 ... T4	125 °C (254 °F)	85 °C (185 °F)
T5	90 °C (194 °F)	82 °C (179.6 °F)
T6	75 °C (167 °F)	67 °C (152.6 °F)

Maximum process temperature T_{medium}

Temperature class	Use in Zone 0	Use in Zone 1
T1	358 °C (676.4 °F)	438 °C (820.4 °F)
T2	238 °C (460.4 °F)	288 °C (550.4 °F)
T3	158 °C (316.4 °F)	193 °C (379.4 °F)
T4	106 °C (222.8 °F)	128 °C (262.4 °F)
T5	78 °C (172.4 °F)	93 °C (199.4 °F)
T6	66 °C (150.8 °F)	78 °C (172.4 °F)

**Dust explosion protection (enclosure)
(only TSP3X1)**

The power feed can come from a power supply unit with an intrinsically-safe output current circuit of type of protection "Ex ia IIB" or "Ex ia IIC", or can be non-intrinsically safe. In the case of a non-intrinsically-safe power feed, the current must be limited by an upstream fuse with a fuse nominal current of 32 mA. The output circuit current of the transmitter (sensor circuit current) is to be limited to a maximum power of 0.5 W. Highest value of thermal data for connection to an intrinsically-safe power supply unit of type of protection "Ex ia IIB / IIC"; refer to the "Thermal data" table.

NOTICE

When using two transmitters and/or measuring insets, the sum of the voltages, currents and outputs must not exceed the values specified in the type examination certificate.

SensyTemp TSP311, TSP321, TSP331

Temperature sensors

Thermal data

	Approved ambient temperature at connection head	Approved process temperature at thermowell	Maximum temperature at the process connection on the connection head side	Maximum surface temperature at the connection head	Maximum surface temperature at the thermowell
Category 1D or Category 1/2 with intrinsically-safe transmitter installed	-40 ... 85 °C (-40 ... 185 °F)	-40 ... 85 °C (-40 ... 185 °F) -40 ... 200 °C (-40 ... 392 °F) ¹⁾ -40 ... 300 °C (-40 ... 572 °F) ¹⁾ -40 ... 400 °C (-40 ... 752 °F) ¹⁾	85 °C (185 °F) 164 °C (327.2 °F) 251 °C (483.8 °F) 346 °C (654.8 °F)	120 °C (248 °F)	133 °C (271.4 °F) 200 °C (392 °F) 300 °C (572 °F) 400 °C (752 °F)
Category 1D or Category 1/2 with fuse protection of installed transmitter by means of external IEC fuse	-40 ... 85 °C (-40 ... 185 °F)	-40 ... 85 °C (-40 ... 185 °F) -40 ... 200 °C (-40 ... 392 °F) ¹⁾ -40 ... 300 °C (-40 ... 572 °F) ¹⁾ -40 ... 400 °C (-40 ... 752 °F) ¹⁾	85 °C (185 °F) 164 °C (327.2 °F) 251 °C (483.8 °F) 346 °C (654.8 °F)	133 °C (271.4 °F) ²⁾ 150 °C (302 °F) ³⁾	133 °C (271.4 °F) 200 °C (392 °F) 300 °C (572 °F) 400 °C (752 °F)
Category 1D or category 1/2D measuring loop, intrinsically-safe transmitter, external or non-intrinsically-safe by means of external IEC fuse in the power feed circuit of the external transmitter	-40 ... 85 °C (-40 ... 185 °F) -40 ... 120 °C (-40 ... 248 °F) -40 ... 120 °C (-40 ... 248 °F) -40 ... 120 °C (-40 ... 248 °F)	-40 ... 85 °C (-40 ... 185 °F) -40 ... 200 °C (-40 ... 392 °F) -40 ... 300 °C (-40 ... 572 °F) -40 ... 400 °C (-40 ... 752 °F)	85 °C (185 °F) 200 °C (392 °F) 251 °C (483.8 °F) 346 °C (654.8 °F)	85 °C (185 °F) 200 °C (392 °F) 200 °C (392 °F) 200 °C (392 °F)	133 °C (271.4 °F) 200 °C (392 °F) 300 °C (572 °F) 400 °C (752 °F)

1) The user must take suitable measures to ensure that the maximum permissible ambient temperature of 85 °C (185 °F) at the connection head is not exceeded.

2) Fitted with a transmitter with and without display.

3) Fitted with two transmitters.

Non-sparking and dust explosion protection

External measures must be made for the power supply circuit in order to prevent the rated voltage from being exceeded by more than 40% in the event of transient disturbances.

The ambient temperature depends on the process temperature. The lower limit is -40 °C (-40 °F). The upper limit of the ambient temperature is presented in the following table:

Process temperature	Extension tube 150 mm	Extension tube 250 mm
100 °C (212 °F)	65 °C (149 °F)	70 °C (158 °F)
200 °C (392 °F)	60 °C (140 °F)	70 °C (158 °F)
300 °C (572 °F)	60 °C (140 °F)	70 °C (158 °F)
400 °C (752 °F)	55 °C (131 °F)	65 °C (149 °F)

For integrated TTH200 or TTH300 transmitters and the T6 temperature class, the maximum permissible ambient temperature is 56 °C (132.8 °F).

Process temperature: max. 400 °C (752 °F) for II 3G
max. 300 °C (572 °F) for II 3D

Tests and certificates

To increase the safety and accuracy of your process, ABB provides a number of mechanical and electrical tests. The results of these tests are certified in accordance with EN 10204.

The following certificates are issued:

- Declaration of compliance 2.1 for order conformity
- Test report 2.2 for the following tests:
 - Material of wetted parts
 - Batch values of the thermocouple
 - Insulation resistance measurement at room temperature
- Inspection certificate 3.1 for the following tests:
 - Material confirmation for wetted parts
 - Visual, dimensional and function checks of temperature sensor
 - Helium leak test for thermowell
 - X-ray inspection of thermowell for bore hole concentricity on request
 - X-ray inspection of weld seams
 - Ultrasonic test for bore hole concentricity
 - Dye penetration test at the weld seams of the thermowell
 - Compression test of thermowell
 - Measuring inset reference measurement

- Inspection certificate 3.2 available on request

For measurements requiring extremely high accuracy, ABB can calibrate the temperature sensor in its own DAkkS-calibration lab.

When DAkkS- calibration is performed, a separate certificate is provided for each temperature sensor.

Reference measurements and DAkkS calibrations are performed on the measuring inset, together with a transmitter if necessary.

To obtain accurate measurements, observe the minimum length for the measuring inset's mineral insulated cable:

- In very low temperatures (< -70° C (-94 °F)): 300 mm
- In low to medium temperatures: 100 ... 150 mm
- In temperatures over 500 °C (932 °F): 300 ... 400 mm

Longer lengths allow additional measurement methods and simplify the measuring process. If you require any further information, please contact your local ABB partner.

For reference measurements and DAkkS-calibration, the individual characteristic of the temperature sensor can also be calculated and a suitable transmitter can be programmed based on a freestyle characteristic. Adjusting the transmitter to the sensor characteristic can considerably improve the measuring accuracy of the temperature sensor. The measurement must be taken with at least three temperatures.

SensyTemp TSP311, TSP321, TSP331

Temperature sensors

Ordering Information

IMPORTANT (NOTICE)

Order codes cannot be combined at will. Your ABB partner will be happy to answer any questions you might have regarding installation feasibility. All documentation, declarations of conformity, and certificates are available in ABB's download area.

Main ordering information SensyTemp TSP311

Base model	TSP311	XX	XX	XX	XX	XX	XX	XX	XX	XX	XX
SensyTemp TSP311 Temperature Sensor, without thermowell, for heavy duty applications											
Explosion Protection / Approvals											
Without		Y0									
Intrinsic Safety ATEX II 1 G Ex ia IIC T6 Ga or II 2 G Ex ib IIC T6 Gb or II 1/2 G Ex ib IIC T6 Ga/Gb		A1									
Dust ignition proof ATEX II 1 D IP6x		A3									
Dust ignition proof ATEX II 1 D IP6X T133 ... T400 and Intrinsic Safety ATEX II 1 G Ex ia IIC T6 ... T1-Zone 0, 1, 2, 20, 21, 22	1)	A4									
Flameproof enclosure ATEX II 1/2 G Ex d IIC T1 - T6 Ga/Gb		A5									
Non incendive ATEX II 3 G Ex nA IIC T1 - T6 Gc and ATEX II 3 D Ex tc IIIB T133°C Dc	1)	B1									
Dust ignition proof ATEX II 1 D IP6X T133 and Flameproof enclosure ATEX II 1/2 G Ex d IIC T6 - Zone 1, 2, 20, 21, 22	1)	B5									
Intrinsic Safety IECEx ia IIC T6 Ga		H1									
Intrinsic Safety IECEx ib IIC T6 Gb or IECEx ib IIC T6 Ga/Gb		H2									
Flameproof enclosure IECEx d IIC T1 - T6 Ga/Gb		H5									
Intrinsic Safety acc. NAMUR NE 24 and ATEX II 1 G Ex ia IIC T6 Ga		N1									
GOST Russia - metrological approval		G1									
GOST Russia - metrological approval and EAC-Ex, Ex i - Zone 0		P2									
GOST Russia - metrological approval and EAC-Ex, Ex d		P3									
GOST Russia - metrological approval and EAC-Ex, dust ignition proof		P4									
GOST Kazakhstan - metrological approval		G3									
GOST Kazakhstan - metrological approval and EAC-Ex, Ex i - Zone 0		T2									
GOST Kazakhstan - metrological approval and EAC-Ex, Ex d		T3									
GOST Kazakhstan - metrological approval and EAC-Ex, dust ignition proof		T4									
GOST Belarus - metrological approval		M5									
GOST Belarus - metrological approval and EAC-Ex, Ex i - Zone 0		U2									
GOST Belarus - metrological approval and EAC-Ex, Ex d		U3									
GOST Belarus - metrological approval and EAC-Ex, dust ignition proof		U4									
Extension Tube Length											
Without Extension Tube		Y0									
K = 150 mm (6 in.)		K1									
Customer specific length		Z9									

Continued see next page

Main ordering information SensyTemp TSP311	XX	XX	XX	XX	XX	XX	XX	XX
Thermowell Connection								
No extension / Connection head with thread M24 x 1,5	W1							
No extension / Connection head with thread 1/2 in. NPT	W2							
No extension / Connection head with lock nut M24 x 1.5	W3							
Double nipple / G 1/2 A / G 1/2 A	W4							
Double nipple / 1/2 in. NPT / 1/2 in. NPT	W5							
Extension tube with Cylindrical thread G 1/2 A	G1							
Extension tube with Cylindrical thread G 3/4 A	G2							
Extension tube with Cylindrical thread G 3/8 A	G3							
Extension tube with Cylindrical thread M14 x 1,5	M1							
Extension tube with Cylindrical thread M18 x 1,5	M2							
Extension tube with Cylindrical thread M20 x 1,5	M3							
Extension tube with Cylindrical thread M24 x 1,5	M4							
Extension tube with Cylindrical thread M27 x 2	M5							
Extension tube with conycal thread 1/2 in. NPT	N1							
Nipple / 1/2 in. NPT / 1/2 in. NPT	N2							
Nipple-Union / 1/2 in. NPT / Union 1/2 in. NPT	N3							
Nipple - Union - Nipple / 1/2 in. NPT / 1/2 in. NPT	N4							
Extension with Male nut, thread G 1/2 in.	U6							
Extension tube with adjustable compression fitting G 1/2 A	A1							
Extension tube with adjustable compression fitting 1/2 in. NPT	A2							
Others	Z9							
Immersion Length								
U = 140 mm (5.6 in.)		U2						
U = 200 mm (8 in.)		U4						
U = 260 mm (10.3 in.)		U6						
Customer specific length		Z9						

Continued see next page

SensyTemp TSP311, TSP321, TSP331

Temperature sensors

Main ordering information SensyTemp TSP311	XX	XX	XX	XX	XX	XX
Measuring Inset Type						
RTD, TF, Basic application, measuring range -50 ... 400 °C (-58 ... 752 °F), 10 g	S1					
RTD, TF, Extended vibration resistance, measuring range -50 ... 400 °C (-58 ... 752 °F), 60 g	S2					
RTD, TF, Extended measuring range -196 ... 400 °C (-321 ... 752 °F), 10 g	S3					
RTD, TF, Extended vibration resistance, extended measuring range -196 ... 400 °C (-321 ... 752 °F), 60 g	S4					
RTD, WW, Extended measuring range -196 ... 600 °C (-321 ... 1112 °F), 10 g	D1					
RTD, WW, Extended vibration resistance, extended measuring range -196 ... 600 °C (-321 ... 1112 °F), 60 g	D3					
RTD, adjustable to German calibration regulations, sign of app. 000/308 - without calibration	E1					
RTD, custody preliminary, adjustable to German calibration regulations, sign of app. 000/308 - with calibration -10 °C and +50 °C	E2					
Thermocouple	T1					
Others	Z9					
Measuring Inset Diameter						
3 mm				D3		
4.5 mm				D4		
6 mm				D6		
8 mm				D8		
8 mm, tip with sleeve, DIN 43735 Sleeve 80 mm (RTD), 20 mm (TC)				H8		
10 mm, tip with sleeve Sleeve 80 mm (RTD), 20 mm (TC)				H1		
Others				Z9		
Sensor Type and Wiring						
1 x Pt100, 2-wire					P1	
1 x Pt100, 3-wire					P2	
1 x Pt100, 4-wire					P3	
2 x Pt100, 2-wire					P4	
2 x Pt100, 3-wire					P5	
2 x Pt100, 4-wire					P6	
1 x Pt1000, 2-wire					P8	
1 x Pt1000, 3-wire					P7	
1 x Pt1000, 4-wire					P9	
1 x Type K (NiCr-NiAl)					K1	
2 x Type K (NiCr-NiAl)					K2	
3 x Type K (NiCr-NiAl)					K3	
1 x Type J (Fe-CuNi)					J1	
2 x Type J (Fe-CuNi)					J2	
1 x Type L (Fe-CuNi)					L1	
2 x Type L (Fe-CuNi)					L2	
1 x Type N (NiCrSi-NiSi)					N1	
2 x Type N (NiCrSi-NiSi)					N2	
1 x Type T (Cu-CuNi)					T1	
2 x Type T (Cu-CuNi)					T2	
1 x Type E (NiCr-CuNi)					E1	
2 x Type E (NiCr-CuNi)					E2	
1 x Type S (Pt10Rh-Pt)					S1	
2 x Type S (Pt10Rh-Pt)					S2	
Others					Z9	

Continued see next page

Main ordering information SensyTemp TSP311	XX	XX	XX
Sensor Accuracy			
Accuracy Class B, IEC 60751	B2		
Wire Wound, Double, Accuracy Class A, IEC 60751, Range 0 ... 250 °C (32 ... 482 °F)	D2		
Wire Wound, Accuracy Class A, IEC 60751, Range -100 ... 450 °C (-148 ... 842 °F)	D1		
Thin Film, Accuracy Class A, IEC 60751, Range -30 ... 300 °C (-22 ... 572 °F)	S1		
Thin Film, Accuracy Class AA, IEC 60751, Range 0 ... 100 °C (0 ... 212 °F)	S3		
Thin Film, Accuracy Class A extended according to IEC 60751, Range -196 ... 400 °C (-320,8 ... 752 °F)	S6		
Thin Film, Accuracy Class AA extended according to IEC 60751, Range -196 ... 400 °C (-320,8 ... 752 °F)	S8		
Thermocouple, Accuracy Class 2, IEC 60584	T2		
Thermocouple, Accuracy Class 1, IEC 60584	T1		
Thermocouple, Standard Accuracy ANSI MC96.1	T4		
Thermocouple, Special Accuracy ANSI MC96.1	T3		
Thermocouple, Accuracy according to DIN 43710	T5		
Others	Z9		
Connection Head Type / Material			
AGL / Aluminium, screwed cover		L1	
AGLH / Aluminium, high cover, screwed		L2	
AGLD / Aluminium, screwed cover with display		L4	
AGS / Stainless steel, screwed cover		S1	
AGSH / Stainless steel, high cover, screwed		S2	
AGSD / Stainless steel, screwed cover with display		S4	
Others		Z9	
Transmitter			
Without transmitter, sensor with ceramic terminal block - spring loaded			Y1
Without transmitter, sensor with flying leads and metal plate - spring loaded			Y2
TTH300-HART, programmable, output signal 4 ... 20 mA, dual input			H4
TTH300-HART, Ex version, programmable, output signal 4 ... 20 mA, dual input			H5
TTH300-PA, programmable, output PROFIBUS PA, dual input			P6
TTH300-PA, Ex version, programmable, output PROFIBUS PA, dual input			P7
TTH300-FF, programmable, output FOUNDATION fieldbus H1, dual input			F6
TTH300-FF, Ex version, programmable, output FOUNDATION fieldbus H1, dual input			F7
TTH200-HART, programmable, output signal 4 ... 20 mA			H6
TTH200-HART, Ex version, programmable, output signal 4 ... 20 mA			H7

SensyTemp TSP311, TSP321, TSP331

Temperature sensors

Additional ordering information SensyTemp TSP311

	XX	XX	XX
Transmitter Measuring Range			
Standard measuring range	A0		
Customer-specific measuring range	AZ		
Certificates			
Declaration of compliance according EN 10204-2.1, with the order			C4
Test report according EN 10204-2.2 for batch values, MIC-TC			C5
Test report according EN 10204-2.2 for measuring of insulaionsresistance at ambient temperature			CN
Inspection certificate according EN 10204-3.1, visual, dimensional and functional test			C6
Inspection certificate according EN 10204-3.1, helium leakage test			C7
Inspection certificate according EN 10204-3.1, sensor tolerance			CC
TÜV certificate for functional safety SIL2 IEC 61508 for sensor with integrated transmitter, HART			CS
Inspection certificate according EN 10204-3.1, sensor calibration, single RTD			CD
Inspection certificate according EN 10204-3.1, sensor calibration, double RTD			CE
Inspection certificate according EN 10204-3.1, sensor calibration, single thermocouple			CF
Inspection certificate according EN 10204-3.1, sensor calibration, double thermocouple			CG
DAkkS sensor calibration, single RTD, calibration certificate per thermometer			CH
DAkkS sensor calibration, double RTD, calibration certificate per thermometer			CJ
DAkkS sensor calibration, single thermocouple, calibration certificate per thermometer			CK
DAkkS sensor calibration, double thermocouple, calibration certificate per thermometer			CL
Others			CZ
Number of Calibration Test Points			
1 point			P1
2 points			P2
3 points			P3
4 points			P4
5 points			P5

Additional ordering information SensyTemp TSP311	XX	XX	XX
Temperatures for Sensor Calibration			
Standard calibration: 0 °C (32 °F)	V1		
Standard calibration: 100 °C (212 °F)	V2		
Standard calibration: 400 °C (752 °F)	V3		
Standard calibration: 0 °C and 100 °C (32 °F and 212 °F)	V4		
Standard calibration: 0 °C and 400 °C (32 °F and 752 °F)	V5		
Standard calibration: 0 °C, 100 °C and 200 °C (32 °F, 212 °F and 392 °F)	V7		
Standard calibration: 0 °C, 200 °C and 400 °C (32 °F, 392 °F and 752 °F)	V8		
Standard calibration: Customer specific temperatures	V6		
DAkkS calibration: 0 °C (32 °F)	D1		
DAkkS calibration: 100 °C (212 °F)	D2		
DAkkS calibration: 400 °C (752 °F)	D3		
DAkkS calibration: 0 °C and 100 °C (32 °F and 212 °F)	D4		
DAkkS calibration: 0 °C and 400 °C (32 °F and 752 °F)	D5		
DAkkS calibration: 0 °C, 100 °C and 200 °C (32 °F, 212 °F and 392 °F)	D7		
DAkkS calibration: 0 °C, 200 °C and 400 °C (32 °F, 392 °F and 752 °F)	D8		
DAkkS calibration: Customer specific temperatures	D6		
Extension Tube Options			
Extension tube welded with measuring inset, gas tight		N3	
Extension tube oil tight up to 3bar		N4	
Mounting bracket		N5	
Threaded Connection Options			
Adjustable compression fitting G 1/4, stainless steel material			K1
Adjustable compression fitting G 1/4, stainless steel material, olive material PTFE			K2
Adjustable compression fitting G 1/2, stainless steel material			K3
Adjustable compression fitting G 1/2, stainless steel material, olive material PTFE			K4
Adjustable compression fitting M18 x 1.5, stainless steel material			K5
Adjustable compression fitting 1/2 in. NPT, stainless steel material			K6
Adjustable compression fitting 1/2 in. NPT, stainless steel material, olive material PTFE			K7
Spring loaded adjustable compression fitting G 1/2 , stainless steel material			K8
Spring loaded adjustable compression fitting M18 x 1.5, stainless steel material			K9
Others			KZ

SensyTemp TSP311, TSP321, TSP331

Temperature sensors

Additional ordering information SensyTemp TSP311	XX	XX	XX	XX	XX
Measuring Inset: Option					
Hot junction grounded	J1				
2 insets paired from 0 ... 100 °C (32 ... 212 °F), max. deviation 0.1 K	J3				
Improvement Sensor Accuracy to 0.5 Cl. A, 0 ... 100°C, U>100 mm	J8				
Improvement Sensor Accuracy to 0.5 Cl. A, 0 ... 400°C, U>250 mm	J9				
Measuring Inset: Transmitter Mounted					
Transmitter mounted on inset, without ceramic block	J2				
Measuring Inset: Other Options					
Others				JZ	
Connection Head Options					
Second transmitter mounted in connection head (same type as first one)					H1
Cover of connection head with chain attached to the lower part					H8
Connection head with capstan screw for sealing					H9
Others					HZ
Cable Entry Options					
1 x M20 x 1.5, without cable gland					U1
1 x 1/2 in. NPT, without cable gland					U2
2 x M20 x 1.5, without cable gland					U4
2 x 1/2 in. NPT, without cable gland					U5
2x M20 x 1.5, with cable gland skintop, temperature range -40 bis +70 °C (-40 bis +158 °F)					U7
1 x M20 x 1.5, with Ex-d cable gland					UA
2 x M20 x 1.5, with Ex-d cable gland					UC
Harting Han 7D plug and socket connection					UG
Harting Han 8D (8U) plug and socket connection					UH
M12 plug for PROFIBUS PA					UJ
7/8 in. plug for FOUNDATION fieldbus					UK
1 x 1/2 in. NPT-PE ADE 4F Capri Codec					UF
1 x 1/2 in. NPT Capri Codec, with strain relief					UL
1 x 1/2 in. NPT-PE ADE 4F + 1 x 1/2 in. NPT plug					UP
Others					UZ

Additional ordering information SensyTemp TSP311	XX	XX	XX	XX	XX
Display Type					
LCD indicator type AS	L1				
Configurable LCD Indicator type A	L2				
Other Options					
With fastened gasket		PD			
Earth screw internal		PH			
Name plate stainless steel		PV			
Each Thermometer single packed - Polyethylen		PN			
Documentation Language					
German			M1		
English			M5		
Language package Western Europe / Scandinavia (Languages: DA, ES, FR, IT, NL, PT, FI, SV)			MW		
Language package Eastern Europe (Languages: EL, CS, ET, LV, LT, HU, HR, PL, SK, SL, RO, BG)			ME		
Additional TAG Plate					
Stainless steel plate with TAG no.					T1
Additional Identification Plate					
Stainless steel plate with customer specific text					T2
Adhesive label					T3

1) According to EN 60079-0 and EN 61241-0, the application in hybrid mixtures (concomitance of potentially explosive dust and gas) is currently not allowed.

SensyTemp TSP311, TSP321, TSP331

Temperature sensors

Main ordering information SensyTemp TSP321

Base model	TSP321	XX	XX	XX	XX	XX	XX	XX	XX	XX	XX	XX	XX	XX
SensyTemp TSP321 Temperature Sensor, with tubular thermowell, for heavy duty applications														
Explosion Protection / Approvals		Continued see next page												
Without		Y0												
Intrinsic Safety ATEX II 1 G Ex ia IIC T6 Ga or II 2 G Ex ib IIC T6 Gb or II 1/2 G Ex ib IIC T6 Ga/Gb		A1												
Dust ignition proof ATEX II 1 D IP6x		A3												
Dust ignition proof ATEX II 1 D IP6X T133 ... T400 and Intrinsic Safety ATEX II 1 G Ex ia IIC T6 ... T1-Zone 0, 1, 2, 20, 21, 22	1)	A4												
Flameproof enclosure ATEX II 1/2 G Ex d IIC T1 - T6 Ga/Gb		A5												
Non incendive ATEX II 3 G Ex nA IIC T1 - T6 Gc and ATEX II 3 D Ex tc IIIB T133°C Dc	1)	B1												
Dust ignition proof ATEX II 1 D IP6X T133 and Flameproof enclosure ATEX II 1/2 G Ex d IIC T6 - Zone 1, 2, 20, 21, 22	1)	B5												
Intrinsic Safety IECEx ia IIC T6 Ga		H1												
Intrinsic Safety IECEx ib IIC T6 Gb or IECEx ib IIC T6 Ga/Gb		H2												
Flameproof enclosure IECEx d IIC T1 - T6 Ga/Gb		H5												
Intrinsic Safety acc. NAMUR NE 24 and ATEX II 1 G Ex ia IIC T6 Ga		N1												
GOST Russia - metrological approval		G1												
GOST Russia - metrological approval and EAC-Ex, Ex i - Zone 0		P2												
GOST Russia - metrological approval and EAC-Ex, Ex d		P3												
GOST Russia - metrological approval and EAC-Ex, dust ignition proof		P4												
GOST Kazakhstan - metrological approval		G3												
GOST Kazakhstan - metrological approval and EAC-Ex, Ex i - Zone 0		T2												
GOST Kazakhstan - metrological approval and EAC-Ex, Ex d		T3												
GOST Kazakhstan - metrological approval and EAC-Ex, dust ignition proof		T4												
GOST Belarus - metrological approval		M5												
GOST Belarus - metrological approval and EAC-Ex, Ex i - Zone 0		U2												
GOST Belarus - metrological approval and EAC-Ex, Ex d		U3												
GOST Belarus - metrological approval and EAC-Ex, dust ignition proof		U4												

Main ordering information SensyTemp TSP321	XX	XX	XXX	XX	XX	XX	XX	XX	XX	XX	XX	XX
Wetted Thermowell Material												
Stainless Steel ASTM 316L (1.4404)	S1											
Stainless Steel ASTM 316Ti (1.4571)	S2											
Highly heat-resistant stainless steel ASTM A446-1 (1.4749)	H1											
Heat Resistent Steel 1.4762	H2											
Stainless Steel AISI 314 (1.4841)	H3											
Duplex stainless steel (CrNi, 1.4462)	S9											
Stainless steel ASTM 904L (CrNi, 1.4539); (Uranus B6)	S4											
Ni-Alloy Hastelloy C-276 (2.4819)	N1											
Ni-Alloy Hastelloy C-4 (2.4610)	N2											
Highly heat-resistant stainless steel , Ni-Alloy Inconel 600 (2.4816)	N5											
Others	Z9											
Thermowell Type												
Tubular thermowell with straight shaft (DIN 43772, Form 2)	A1											
Flanged tubular thermowell with straight shaft (DIN 43772, Form 2F)	A2											
Screwed tubular thermowell with straight shaft (DIN 43772, Form 2G)	A3											
Tubular thermowell, stepped tip (ABB Form 2S)	B1											
Flanged tubular thermowell, stepped tip (ABB Form 2FS)	B2											
Screwed tubular thermowell, stepped tip (ABB Form 2GS)	B3											
Tubular thermowell, tapered (DIN 43772, Form 3)	C1											
Flanged tubular thermowell, tapered (DIN 43772, Form 3F)	C2											
Screwed tubular thermowell, tapered (DIN 43772, Form 3G)	C3											
Screwed tubular thermowell without extension, straight shaft (ABB Form 2G0)	A4											
Screwed tubular thermowell without extension, stepped tip (ABB Form 2GS0)	B4											
Tubular thermowell d= 22mm, stepped tip d= 6mm	B5											
Tubular thermowell, stepped tip 9 mm (0.36 in.) (ABB Form 2S/9)	K1											
Flanged tubular thermowell, stepped tip 9 mm (0.36 in.) (ABB Form 2FS/9)	K2											
Screwed tubular thermowell, stepped tip 9 mm (0.36 in.) (ABB Form 2GS/9)	K3											
Others	Z9											

Continued see next page

SensyTemp TSP311, TSP321, TSP331

Temperature sensors

Main ordering information SensyTemp TSP321	XXX	XX	XX	XX	XX	XX	XX	XX	XX
Process Connection									
Without process connection	Y00	Continued see next page							
Adjustable compression fitting G 1/2, stainless steel	A01								
Adjustable compression fitting 1/2 in. NPT, stainless steel	A02								
Adjustable flange DN 25 PN 10 ... PN 40, EN 1092-1	A03								
Adjustable flange 1 in. 150 lbs, ASME B16.5	A07								
Flange DN 15 PN 10 ... PN 40, EN 1092-1	F01								
Flange DN 20 PN 10 ... PN 40, EN 1092-1	F02								
Flange DN 25 PN 10 ... PN 40, EN 1092-1	F03								
Flange DN 25 PN 63 ... PN100, EN 1092-1	F29								
Flange DN 32 PN 16 ... PN 40, EN 1092-1	F30								
Flange DN 40 PN 10 ... PN 40, EN 1092-1	F04								
Flange DN 40 PN 63 ... PN 100, EN 1092-1	F37								
Flange DN 50 PN 6, EN 1092-1	F06								
Flange DN 50 PN 10 ... PN 40, EN 1092-1	F05								
Flange DN 50 PN 63, EN 1092-1	F33								
Flange DN 50 PN 100, EN 1092-1	F34								
Flange DN 80 PN 16, EN 1092-1	F35								
Flange DN 100 PN 40, EN 1092-1	F36								
Flange 1 in. 150 lbs, ASME B16.5	F07								
Flange 1 in. 300 lbs, ASME B16.5	F08								
Flange 1 in. 600 lbs, ASME B16.5	F09								
Flange 1-1/2 in. 150 lbs, ASME B16.5	F11								
Flange 1-1/2 in. 300 lbs, ASME B16.5	F12								
Flange 1-1/2 in. 600 lbs, ASME B16.5	F13								
Flange 1-1/2 in. 900 / 1500 lbs, ASME B16.5	F14								
Flange 2 in. 150 lbs, ASME B16.5	F15								
Flange 2 in. 300 lbs, ASME B16.5	F16								
Flange 2 in. 600 lbs, ASME B16.5	F17								
Flange 2 in. 900 / 1500 lbs, ASME B16.5	F18								
Cylindrical thread G 3/8 A	S15								
Cylindrical thread G 1/2 A	S01								
Cylindrical thread G 3/4 A	S02								
Cylindrical thread G 1 A	S03								
Cylindrical thread M20 x 1.5	S07								
Cylindrical thread M27 x 2	S08								
Conical thread 1/2 in. NPT	S04								
Conical thread 3/4 in. NPT	S05								
Conical thread 1 in. NPT	S06								
Conical thread 1/2 in. BSPT	S09								
Conical thread 3/4 in. BSPT	S10								
Conical thread 1 in. BSPT	S11								
Others	Z99								

Main ordering information SensyTemp TSP321	XX	XX	XX	XX	XX	XX	XX	XX
Thermowell Diameter								
6 mm x 1 mm	A9							Continued see next page
8 mm x 2 mm	A5							
9 mm x 1 mm	A1							
10 mm x 1,5 mm	A6							
11 mm x 2 mm	A2							
12 mm x 2,5 mm	A3							
13,5 mm x 2,3 mm	B6							
13,7 mm x 2,24 mm	B2							
14 mm x 2,5 mm	A4							
15 mm x 2 mm	A7							
16 mm x 3 mm	A8							
22 mm x 2 mm	B1							
Immersion Length								
Without fixed immersion length					Y0			
U = 100 mm (4 in.)					U1			
U = 160 mm (6.3 in.)					U3			
U = 250 mm (10 in.)					U5			
U = 400 mm (16 in.)					U7			
Customer specific length					Z9			
Nominal Length								
N = 230 mm (9.1 in.)					N1			
N = 290 mm (11.42 in.)					N3			
N = 380 mm (15 in.)					N5			
N = 530 mm (20.9 in.)					N7			
Customer specific length					Z9			
Measuring Inset Type								
Without measuring inset						Y0		
RTD, TF, Basic application, measuring range -50 ... 400 °C (-58 ... 752 °F), 10 g						S1		
RTD, TF, Extended vibration resistance, measuring range -50 ... 400 °C (-58 ... 752 °F), 60 g						S2		
RTD, TF, Extended measuring range -196 ... 400 °C (-321 ... 752 °F), 10 g						S3		
RTD, TF, Extended vibration resistance, extended measuring range -196 ... 400 °C (-321 ... 752 °F), 60 g						S4		
RTD, WW, Extended measuring range -196 ... 600 °C (-321 ... 1112 °F), 10 g						D1		
RTD, WW, Extended vibration resistance, extended measuring range -196 ... 600 °C (-321 ... 1112 °F), 60 g						D3		
RTD, adjustable to German calibration regulations, sign of app. 000/308 - without calibration						E1		
RTD, custody preliminary, adjustable to German calibration regulations, sign of app. 000/308 - with calibration -10 °C and +50 °C						E2		
Thermocouple						T1		
Others						Z9		

SensyTemp TSP311, TSP321, TSP331

Temperature sensors

Main ordering information SensyTemp TSP321	XX	XX	XX	XX
Sensor Type and Wiring				
Without measuring inset	Y0	Continued see next page		
1 x Pt100, 2-wire	P1			
1 x Pt100, 3-wire	P2			
1 x Pt100, 4-wire	P3			
2 x Pt100, 2-wire	P4			
2 x Pt100, 3-wire	P5			
2 x Pt100, 4-wire	P6			
1 x Pt1000, 2-wire	P8			
1 x Pt1000, 3-wire	P7			
1 x Pt1000, 4-wire	P9			
1 x Type K (NiCr-NiAl)	K1			
2 x Type K (NiCr-NiAl)	K2			
3 x Type K (NiCr-NiAl)	K3			
1 x Type J (Fe-CuNi)	J1			
2 x Type J (Fe-CuNi)	J2			
1 x Type L (Fe-CuNi)	L1			
2 x Type L (Fe-CuNi)	L2			
1 x Type N (NiCrSi-NiSi)	N1			
2 x Type N (NiCrSi-NiSi)	N2			
1 x Type T (Cu-CuNi)	T1			
2 x Type T (Cu-CuNi)	T2			
1 x Type E (NiCr-CuNi)	E1			
2 x Type E (NiCr-CuNi)	E2			
1 x Type S (Pt10Rh-Pt)	S1			
2 x Type S (Pt10Rh-Pt)	S2			
Others	Z9			

Main ordering information SensyTemp TSP321	XX	XX	XX
Sensor Accuracy			
Without measuring inset	Y0		
Accuracy Class B, IEC 60751	B2		
Wire Wound, Double, Accuracy Class A, IEC 60751, Range 0 ... 250 °C (32 ... 482 °F)	D2		
Wire Wound, Accuracy Class A, IEC 60751, Range -100 ... 450 °C (-148 ... 842 °F)	D1		
Thin Film, Accuracy Class A, IEC 60751, Range -30 ... 300 °C (-22 ... 572 °F)	S1		
Thin Film, Accuracy Class AA, IEC 60751, Range 0 ... 100 °C (0 ... 212 °F)	S3		
Thin Film, Accuracy Class A extended according to IEC 60751, Range -196 ... 400 °C (-320,8 ... 752 °F)	S6		
Thin Film, Accuracy Class AA extended according to IEC 60751, Range -196 ... 400 °C (-320,8 ... 752 °F)	S8		
Thermocouple, Accuracy Class 2, IEC 60584	T2		
Thermocouple, Accuracy Class 1, IEC 60584	T1		
Thermocouple, Standard Accuracy ANSI MC96.1	T4		
Thermocouple, Special Accuracy ANSI MC96.1	T3		
Thermocouple, Accuracy according to DIN 43710	T5		
Others	Z9		
Connection Head Type / Material			
AGL / Aluminium, screwed cover	L1		
AGLH / Aluminium, high cover, screwed	L2		
AGLD / Aluminium, screwed cover with display	L4		
AGS / Stainless steel, screwed cover	S1		
AGSH / Stainless steel, high cover, screwed	S2		
AGSD / Stainless steel, screwed cover with display	S4		
Others	Z9		
Transmitter			
Without transmitter, sensor with ceramic terminal block - spring loaded			Y1
Without transmitter, sensor with flying leads and metal plate - spring loaded			Y2
TTH300-HART, programmable, output signal 4 ... 20 mA, dual input			H4
TTH300-HART, Ex version, programmable, output signal 4 ... 20 mA, dual input			H5
TTH300-PA, programmable, output PROFIBUS PA, dual input			P6
TTH300-PA, Ex version, programmable, output PROFIBUS PA, dual input			P7
TTH300-FF, programmable, output FOUNDATION fieldbus H1, dual input			F6
TTH300-FF, Ex version, programmable, output FOUNDATION fieldbus H1, dual input			F7
TTH200-HART, programmable, output signal 4 ... 20 mA			H6
TTH200-HART, Ex version, programmable, output signal 4 ... 20 mA			H7

SensyTemp TSP311, TSP321, TSP331

Temperature sensors

Additional ordering information SensyTemp TSP321

	XX	XX	XX
Transmitter Measuring Range			
Standard measuring range	A0		
Customer-specific measuring range	AZ		
Certificates			
Declaration of compliance according EN 10204-2.1, with the order			C4
Test report according EN 10204-2.2, material monitoring for wetted parts			C1
Test report according EN 10204-2.2 for batch values, MIC-TC			C5
Test report according EN 10204-2.2 for measuring of insulation resistance at ambient temperature			CN
Inspection certificate according EN 10204-3.1, material monitoring for wetted parts			C2
Inspection certificate according EN 10204-3.1, visual, dimensional and functional test			C6
Inspection certificate according EN 10204-3.1, helium leakage test			C7
Inspection certificate according EN 10204-3.1, dye penetration test			C9
Inspection certificate according EN 10204-3.1, pressure test on thermowell			CB
Inspection certificate according EN 10204-3.1, sensor tolerance			CC
TÜV certificate for functional safety SIL2 IEC 61508 for sensor with integrated transmitter, HART			CS
Inspection certificate according EN 10204-3.1, sensor calibration, single RTD			CD
Inspection certificate according EN 10204-3.1, sensor calibration, double RTD			CE
Inspection certificate according EN 10204-3.1, sensor calibration, single thermocouple			CF
Inspection certificate according EN 10204-3.1, sensor calibration, double thermocouple			CG
DAkkS sensor calibration, single RTD, calibration certificate per thermometer			CH
DAkkS sensor calibration, double RTD, calibration certificate per thermometer			CJ
DAkkS sensor calibration, single thermocouple, calibration certificate per thermometer			CK
DAkkS sensor calibration, double thermocouple, calibration certificate per thermometer			CL
Inspection certificate according EN 10204-3.1, x-ray- test for weldings			CU
Others			CZ
Number of Calibration Test Points			
1 point			P1
2 points			P2
3 points			P3
4 points			P4
5 points			P5

Additional ordering information SensyTemp TSP321	XX	XX	XX
Temperatures for Sensor Calibration			
Standard calibration: 0 °C (32 °F)	V1		
Standard calibration: 100 °C (212 °F)	V2		
Standard calibration: 400 °C (752 °F)	V3		
Standard calibration: 0 °C and 100 °C (32 °F and 212 °F)	V4		
Standard calibration: 0 °C and 400 °C (32 °F and 752 °F)	V5		
Standard calibration: 0 °C, 100 °C and 200 °C (32 °F, 212 °F and 392 °F)	V7		
Standard calibration: 0 °C, 200 °C and 400 °C (32 °F, 392 °F and 752 °F)	V8		
Standard calibration: Customer specific temperatures	V6		
DAkkS calibration: 0 °C (32 °F)	D1		
DAkkS calibration: 100 °C (212 °F)	D2		
DAkkS calibration: 400 °C (752 °F)	D3		
DAkkS calibration: 0 °C and 100 °C (32 °F and 212 °F)	D4		
DAkkS calibration: 0 °C and 400 °C (32 °F and 752 °F)	D5		
DAkkS calibration: 0 °C, 100 °C and 200 °C (32 °F, 212 °F and 392 °F)	D7		
DAkkS calibration: 0 °C, 200 °C and 400 °C (32 °F, 392 °F and 752 °F)	D8		
DAkkS calibration: Customer specific temperatures	D6		
Thermowell Options			
Thermowell stainless steel with additional tantalum sleeve	S1		
Thermowell coated with 0.5 mm (0.02 in.) E-CTFE / Halar, wetted parts incl. flange surface	S2		
Thermowell coated with 0.5 mm (0.02 in.) PFA, wetted parts incl. flange surface	S3		
Thermowell coated with 1 mm (0.04 in.) NiCrB / META 43	2) S4		
Thermowell coated with 0.5 mm (0.02 in.) NiZrO2 / PL1312	2) S5		
Thermowell incl. tests and certificates AD-2000 standard for austenitic steel	S6		
Thermowell incl. tests and certificates AD-2000 standard for high temperature steel	S7		
Thermowell clean for oxygen service	S9		
Thermowell stress calculation according Dittrich / Kohler	SD		
Others	SZ		
Flange Connection Options			
Flange raised face form RF, ASME B16.5			F6
Flange raised face form B1 acc. EN 1092-1			F7
Flange raised face form B2 acc. EN 1092-1			F8
Flange facing with tongue form C EN 1092-1			F1
Flange facing with groove form D acc. EN 1092-1			F2
Flange facing with RTJ surface acc. ASME B16.5			F3
Others			FZ

SensyTemp TSP311, TSP321, TSP331

Temperature sensors

Additional ordering information SensyTemp TSP321	XX	XX	XX	XX	XX	XX
Extension Tube Options						
Mounting bracket	N5					
Measuring Inset: Option						
Hot junction grounded		J1				
2 insets paired from 0 ... 100 °C (32 ... 212 °F), max. deviation 0.1 K		J3				
Improvement Sensor Accuracy to 0.5 Cl. A, 0 ... 100°C, U>100 mm		J8				
Improvement Sensor Accuracy to 0.5 Cl. A, 0 ... 400°C, U>250 mm		J9				
Measuring Inset: Transmitter Mounted						
Transmitter mounted on inset, without ceramic block				J2		
Measuring Inset: Other Options						
Others					JZ	
Connection Head Options						
Second transmitter mounted in connection head (same type as first one)						H1
Cover of connection head with chain attached to the lower part						H8
Connetion head with capstan screw for sealing						H9
Others						HZ
Cable Entry Options						
1 x M20 x 1.5, without cable gland						U1
1 x 1/2 in. NPT, without cable gland						U2
2 x M20 x 1.5, without cable gland						U4
2 x 1/2 in. NPT, without cable gland						U5
2x M20 x 1.5, with cable gland skintop, temperature range -40 bis +70 °C (-40 bis +158 °F)						U7
1 x M20 x 1.5, with Ex-d cable gland						UA
2 x M20 x 1.5, with Ex-d cable gland						UC
Harting Han 7D plug and socket connection						UG
Harting Han 8D (8U) plug and socket connection						UH
M12 plug for PROFIBUS PA						UJ
7/8 in. plug for FOUNDATION fieldbus						UK
1 x 1/2 in. NPT-PE ADE 4F Capri Codec						UF
1 x 1/2 in. NPT Capri Codec, with strain relief						UL
1 x 1/2 in. NPT-PE ADE 4F + 1 x 1/2 in. NPT plug						UP
Others						UZ

Additional ordering information SensyTemp TSP321	XX	XX	XX	XX	XX
Display Type					
LCD indicator type AS	L1				
Configurable LCD Indicator type A	L2				
Other Options					
Earth screw internal		PH			
Name plate stainless steel		PV			
Each Thermometer single packed - Polyethylen		PN			
Documentation Language					
German			M1		
English			M5		
Language package Western Europe / Scandinavia (Languages: DA, ES, FR, IT, NL, PT, FI, SV)			MW		
Language package Eastern Europe (Languages: EL, CS, ET, LV, LT, HU, HR, PL, SK, SL, RO, BG)			ME		
Additional TAG Plate					
Stainless steel plate with TAG no.					T1
Additional Identification Plate					
Stainless steel plate with customer specific text					T2
Adhesive label					T3

- 1) According EN 60079-0 and EN 61241-0, the application in hybrid mixtures (concomitance of potentially explosive dust and gas) is currently not allowed.
2) Specify length from thermowell tip in mm.

SensyTemp TSP311, TSP321, TSP331

Temperature sensors

Main ordering information SensyTemp TSP331

Base model	TSP331	XX	XX	XX	XXX	XX	XX	XX	XX	XX	XX	XX	XX	XX
SensyTemp TSP331 Temperature Sensor, with drilled thermowell, for heavy duty applications														
Explosion Protection / Approvals		Continued see next page												
Without		Y0												
Intrinsic Safety ATEX II 1 G Ex ia IIC T6 Ga or II 2 G Ex ib IIC T6 Gb or II 1/2 G Ex ib IIC T6 Ga/Gb		A1												
Dust ignition proof ATEX II 1 D IP6x		A3												
Dust ignition proof ATEX II 1 D IP6X T133 ... T400 and Intrinsic Safety ATEX II 1 G Ex ia IIC T6 ... T1-Zone 0, 1, 2, 20, 21, 22	1)	A4												
Flameproof enclosure ATEX II 1/2 G Ex d IIC T1 - T6 Ga/Gb		A5												
Non incendive ATEX II 3 G Ex nA IIC T1 - T6 Gc and ATEX II 3 D Ex tc IIIB T133°C Dc	1)	B1												
Dust ignition proof ATEX II 1 D IP6X T133 and Flameproof enclosure ATEX II 1/2 G Ex d IIC T6 - Zone 1, 2, 20, 21, 22	1)	B5												
Intrinsic Safety IECEx ia IIC T6 Ga		H1												
Intrinsic Safety IECEx ib IIC T6 Gb or IECEx ib IIC T6 Ga/Gb		H2												
Flameproof enclosure IECEx d IIC T1 - T6 Ga/Gb		H5												
Intrinsic Safety acc. NAMUR NE 24 and ATEX II 1 G Ex ia IIC T6 Ga		N1												
GOST Russia - metrological approval		G1												
GOST Russia - metrological approval and EAC-Ex, Ex i - Zone 0		P2												
GOST Russia - metrological approval and EAC-Ex, Ex d		P3												
GOST Russia - metrological approval and EAC-Ex, dust ignition proof		P4												
GOST Kazakhstan - metrological approval		G3												
GOST Kazakhstan - metrological approval and EAC-Ex, Ex i - Zone 0		T2												
GOST Kazakhstan - metrological approval and EAC-Ex, Ex d		T3												
GOST Kazakhstan - metrological approval and EAC-Ex, dust ignition proof		T4												
GOST Belarus - metrological approval		M5												
GOST Belarus - metrological approval and EAC-Ex, Ex i - Zone 0		U2												
GOST Belarus - metrological approval and EAC-Ex, Ex d		U3												
GOST Belarus - metrological approval and EAC-Ex, dust ignition proof		U4												

Main ordering information SensyTemp TSP331	XX	XX	XXX	XX	XX	XX	XX	XX	XX	XX	XX	XX	XX
Wetted Thermowell Material			Continued see next page										
Stainless steel ASTM 316L (1.4404)	S1												
Stainless steel ASTM 316Ti (1.4571)	S2												
Heat-resistant stainless steel ASTM A182 F12 (1.7335)	W1												
Heat-resistant stainless steel ASTM A182 F22 (1.7380)	W2												
Heat-resistant stainless steel ASTM A182 F1 (1.5415)	W3												
Highly heat-resistant stainless steel ASTM A347 H (1.4961)	W4												
Highly heat-resistant stainless steel ASTM A446-1 (1.4749)	H1												
Heat resistant steel ASTM A446 (1.4762)	H2												
Heat resistant steel ASTM A314 (CrNi, 1.4841)	H3												
Duplex stainless steel (CrNi, 1.4462)	S9												
Stainless steel ASTM 904L (CrNi, 1.4539); (Uranus B6)	S4												
Ni-Alloy Hastelloy C-276 (2.4819)	N1												
Ni-Alloy Hastelloy C-4 (2.4610)	N2												
NiCu-Alloy Monel 400 (2.4360)	N4												
Ni-Alloy Incoloy 800 (1.4876)	H4												
Highly heat-resistant stainless steel , Ni-Alloy Inconel 600 (2.4816)	N5												
Highly heat-resistant stainless steel ASTM A182 F91 (1.4903)	W5												
Stainless steel ASTM 304 (CrNi, 1.4301)	S5												
Stainless steel ASTM 321 (CrNi, 1.4541)	S6												
Carbon steel ASTM A105 (1.0460)	C1												
Others	Z9												
Thermowell Type													
Weld-in thermowell from bar stock material, diameter F2 = 24 mm (0.95 in.), (DIN 43772, Form 4)	D1												
Weld-in thermowell from bar stock material, diameter F2 = 18 mm (0.71 in.), (DIN 43772, Form 4)	D2												
Flanged thermowell from bar stock material, diameter F2 = 24 mm (0.95 in.), (DIN 43772, Form 4F)	D3												
Flanged thermowell from bar stock material, diameter F2 = 18 mm (0.71 in.), (ABB-Form 4FS)	D4												
Weld-in thermowell from bar stock material, diameter F2 = 26 mm (1.02 in.), (DIN 43772, Form 4)	D5												
Flanged thermowell from bar stock material, diameter F2 = 26 mm (1.02 in.), (DIN 43772, Form 4F)	D6												
Weld-in thermowell from bar stock material, (ABB, Form DR)	R1												
Flanged thermowell from bar stock material, (ABB, Form DRF)	R2												
Weld-in thermowell from bar stock material, (ABB, Form RD)	R3												
Flanged thermowell from bar stock material, (ABB, Form RDF)	R4												
Weld-in thermowell from bar stock material, (ABB, Form PW)	P1												
Flanged thermowell from bar stock material, (ABB, Form PF)	P2												
Screwed thermowell from bar stock material, tapered tip, (ABB, Form PS)	P3												
Screwed tubular thermowell from bar stock material, straight shaft (DIN 43772, Form 6)	S1												
Others	Z9												

SensyTemp TSP311, TSP321, TSP331

Temperature sensors

Main ordering information SensyTemp TSP331	XXX	XX	XX	XX	XX	XX	XX	XX	XX	XX	
Process Connection		Continued see next page									
Without process connection	Y00										
Flange DN 25 PN 10 ... PN 40, EN 1092-1	F03										
Flange DN 25 PN 63 ... PN100, EN 1092-1	F29										
Flange DN 32 PN 16 ... PN 40, EN 1092-1	F30										
Flange DN 40 PN 10 ... PN 40, EN 1092-1	F04										
Flange DN 40 PN 63 ... PN 100, EN 1092-1	F37										
Flange DN 50 PN 6, EN 1092-1	F06										
Flange DN 50 PN 10 ... PN 40, EN 1092-1	F05										
Flange DN 50 PN 63, EN 1092-1	F33										
Flange DN 50 PN 100, EN 1092-1	F34										
Flange DN 80 PN 16, EN 1092-1	F35										
Flange DN 100 PN 40, EN 1092-1	F36										
Flange 1 in. 150 lbs, ASME B16.5	F07										
Flange 1 in. 300 lbs, ASME B16.5	F08										
Flange 1 in. 600 lbs, ASME B16.5	F09										
Flange 1-1/2 in. 150 lbs, ASME B16.5	F11										
Flange 1-1/2 in. 300 lbs, ASME B16.5	F12										
Flange 1-1/2 in. 600 lbs, ASME B16.5	F13										
Flange 1-1/2 in. 900 / 1500 lbs, ASME B16.5	F14										
Flange 2 in. 150 lbs, ASME B16.5	F15										
Flange 2 in. 300 lbs, ASME B16.5	F16										
Flange 2 in. 600 lbs, ASME B16.5	F17										
Flange 2 in. 900 / 1500 lbs, ASME B16.5	F18										
Conical thread 1/2 in. NPT	S04										
Conical thread 3/4 in. NPT	S05										
Conical thread 1 in. NPT	S06										
Others	Z99										

Main ordering information SensyTemp TSP331	XX	XX	XX	XX	XX	XX	XX	XX	XX
Extension Tube Length									
K = 150 mm (6 in.)	K1								
Customer specific length	Z9								
Thermowell Connection									
Extension tube with Cylindrical thread G 1/2 A		G1							
Extension tube with Cylindrical thread G 3/4 A		G2							
Extension tube with Cylindrical thread G 3/8 A		G3							
Extension tube with Cylindrical thread M14 x 1,5		M1							
Extension tube with Cylindrical thread M18 x 1,5		M2							
Extension tube with Cylindrical thread M20 x 1,5		M3							
Extension tube with Cylindrical thread M24 x 1,5		M4							
Extension tube with conycal thread 1/2 in. NPT		N1							
Nipple / 1/2 in. NPT / 1/2 in. NPT		N2							
Nipple-Union / 1/2 in. NPT / Union 1/2 in. NPT		N3							
Nipple - Union - Nipple / 1/2 in. NPT / 1/2 in. NPT		N4							
Extension with Male nut, thread G 1/2 in.		U6							
Others		Z9							
Immersion Length									
Without fixed immersion length		Y0							
U = 130 mm (5.2 in.)		D1							
U = 190 mm (7.5 in.)		D2							
U = 340 mm (13.4 in.)		D3							
U = 100 mm (4 in.)		P1							
U = 150 mm (6 in.)		P2							
U = 200 mm (8 in.)		P3							
U = 250 mm (10 in.)		P4							
U = 300 mm (12 in.)		P5							
U = 350 mm (14 in.)		P6							
Customer specific length		Z9							

Continued see next page

SensyTemp TSP311, TSP321, TSP331

Temperature sensors

Main ordering information SensyTemp TSP331	XX	XX	XX	XX	XX	XX
Thermowell Length						
L = 110 mm (4.4 in.), C = 65 mm (2.5 in.)	D1					
L = 115 mm (4.6 in.), C = 40 mm (1.5 in.)	D2					
L = 140 mm (5.6 in.), C = 65 mm (2.5 in.)	D3					
L = 200 mm (8 in.), C = 65 mm (2.5 in.)	D4					
L = 200 mm (8 in.), C = 125 mm (5 in.)	D5					
L = 260 mm (10.3 in.), C = 125 mm (5 in.)	D6					
L = 410 mm (16.2 in.), C = 275 mm (10.9 in.)	D7					
L = 146 mm (5.8 in.)	R1					
L = 175 mm (6.9 in.)	R2					
L = 265 mm (10.5 in.)	R3					
L = 415 mm (16.4 in.)	R4					
L = U + 65 mm (2.5 in.) - ABB-standard	P1					
Acc. customer specification	D9					
Customer specific length	Z9					
Measuring Inset Type						
Without measuring inset	Y0					
RTD, TF, Basic application, measuring range -50 ... 400 °C (-58 ... 752 °F), 10 g	S1					
RTD, TF, Extended vibration resistance, measuring range -50 ... 400 °C (-58 ... 752 °F), 60 g	S2					
RTD, TF, Extended measuring range -196 ... 400 °C (-321 ... 752 °F), 10 g	S3					
RTD, TF, Extended vibration resistance, extendend measuring range -196 ... 400 °C (-321 ... 752 °F), 60 g	S4					
RTD, WW, Extended measuring range -196 ... 600 °C (-321 ... 1112 °F), 10 g	D1					
RTD, WW, Extended vibration resistance, extendend measuring range -196 ... 600 °C (-321 ... 1112 °F), 60 g	D3					
RTD, adjustable to German calibration regulations, sign of app. 000/308 - without calibration	E1					
RTD, custody preliminary, adjustable to German calibration regulations, sign of app. 000/308 - with calibration -10 °C and +50 °C	E2					
Thermocouple	T1					
Others	Z9					

Continued see next
page

Main ordering information SensyTemp TSP331	XX	XX	XX	XX	
Sensor Type and Wiring					
Without measuring inset	Y0	Continued see next page			
1 x Pt100, 2-wire	P1				
1 x Pt100, 3-wire	P2				
1 x Pt100, 4-wire	P3				
2 x Pt100, 2-wire	P4				
2 x Pt100, 3-wire	P5				
2 x Pt100, 4-wire	P6				
1 x Pt1000, 2-wire	P8				
1 x Pt1000, 3-wire	P7				
1 x Pt1000, 4-wire	P9				
1 x Type K (NiCr-NiAl)	K1				
2 x Type K (NiCr-NiAl)	K2				
3 x Type K (NiCr-NiAl)	K3				
1 x Type J (Fe-CuNi)	J1				
2 x Type J (Fe-CuNi)	J2				
1 x Type L (Fe-CuNi)	L1				
2 x Type L (Fe-CuNi)	L2				
1 x Type N (NiCrSi-NiSi)	N1				
2 x Type N (NiCrSi-NiSi)	N2				
1 x Type T (Cu-CuNi)	T1				
2 x Type T (Cu-CuNi)	T2				
1 x Type E (NiCr-CuNi)	E1				
2 x Type E (NiCr-CuNi)	E2				
1 x Type S (Pt10Rh-Pt)	S1				
2 x Type S (Pt10Rh-Pt)	S2				
Others	Z9				
Sensor Accuracy					
Without measuring inset	Y0				
Accuracy Class B, IEC 60751	B2				
Wire Wound, Double, Accuracy Class A, IEC 60751, Range 0 ... 250 °C (32 ... 482 °F)	D2				
Wire Wound, Accuracy Class A, IEC 60751, Range -100 ... 450 °C (-148 ... 842 °F)	D1				
Thin Film, Accuracy Class A, IEC 60751, Range -30 ... 300 °C (-22 ... 572 °F)	S1				
Thin Film, Accuracy Class AA, IEC 60751, Range 0 ... 100 °C (0 ... 212 °F)	S3				
Thin Film, Accuracy Class A extended according to IEC 60751, Range -196 ... 400 °C (-320,8 ... 752 °F)	S6				
Thin Film, Accuracy Class AA extended according to IEC 60751, Range -196 ... 400 °C (-320,8 ... 752 °F)	S8				
Thermocouple, Accuracy Class 2, IEC 60584	T2				
Thermocouple, Accuracy Class 1, IEC 60584	T1				
Thermocouple, Standard Accuracy ANSI MC96.1	T4				
Thermocouple, Special Accuracy ANSI MC96.1	T3				
Thermocouple, Accuracy according to DIN 43710	T5				
Others	Z9				

SensyTemp TSP311, TSP321, TSP331

Temperature sensors

Main ordering information SensyTemp TSP331		XX	XX
Connection Head Type / Material			
AGL / Aluminium, screwed cover		L1	
AGLH / Aluminium, high cover, screwed		L2	
AGLD / Aluminium, screwed cover with display		L4	
AGS / Stainless steel, screwed cover		S1	
AGSH / Stainless steel, high cover, screwed		S2	
AGSD / Stainless steel, screwed cover with display		S4	
Others		Z9	
Transmitter			
Without transmitter, sensor with ceramic terminal block - spring loaded		Y1	
Without transmitter, sensor with flying leads and metal plate - spring loaded		Y2	
TTH300-HART, programmable, output signal 4 ... 20 mA, dual input		H4	
TTH300-HART, Ex version, programmable, output signal 4 ... 20 mA, dual input		H5	
TTH300-PA, programmable, output PROFIBUS PA, dual input		P6	
TTH300-PA, Ex version, programmable, output PROFIBUS PA, dual input		P7	
TTH300-FF, programmable, output FOUNDATION fieldbus H1, dual input		F6	
TTH300-FF, Ex version, programmable, output FOUNDATION fieldbus H1, dual input		F7	
TTH200-HART, programmable, output signal 4 ... 20 mA		H6	
TTH200-HART, Ex version, programmable, output signal 4 ... 20 mA		H7	

Additional ordering information SensyTemp TSP331

	XX	XX	XX
Transmitter Measuring Range			
Standard measuring range	A0		
Customer-specific measuring range	AZ		
Certificates			
Declaration of compliance according EN 10204-2.1, with the order			C4
Test report according EN 10204-2.2, material monitoring for wetted parts			C1
Test report according EN 10204-2.2 for batch values, MIC-TC			C5
Test report according EN 10204-2.2 for measuring of insulationsresistance at ambient temperature			CN
Inspection certificate according EN 10204-3.1, material monitoring for wetted parts			C2
Inspection certificate according EN 10204-3.2, material monitoring for wetted parts			C3
Inspection certificate according EN 10204-3.1, visual, dimensional and functional test			C6
Inspection certificate according EN 10204-3.1, helium leakage test			C7
Inspection certificate according EN 10204-3.1, dye penetration test			C9
Inspection certificate according EN 10204-3.1, Positive Material Identification (PMI)			CA
Inspection certificate according EN 10204-3.1, pressure test on thermowell			CB
Inspection certificate according EN 10204-3.1, sensor tolerance			CC
TÜV certificate for functional safety SIL2 IEC 61508 for sensor with integrated transmitter, HART			CS
Inspection certificate according EN 10204-3.1, sensor calibration, single RTD			CD
Inspection certificate according EN 10204-3.1, sensor calibration, double RTD			CE
Inspection certificate according EN 10204-3.1, sensor calibration, single thermocouple			CF
Inspection certificate according EN 10204-3.1, sensor calibration, double thermocouple			CG
DAkkS sensor calibration, single RTD, calibration certificate per thermometer			CH
DAkkS sensor calibration, double RTD, calibration certificate per thermometer			CJ
DAkkS sensor calibration, single thermocouple, calibration certificate per thermometer			CK
DAkkS sensor calibration, double thermocouple, calibration certificate per thermometer			CL
Inspection certificate according EN 10204-3.1, x-ray- test for weldings			CU
Inspection certificate according EN 10204-3.1, x-ray- test for bore concentricity			CV
Inspection certificate according EN 10204-3.1, ultrasonic- test for bore concentricity			CW
Others			CZ
Number of Calibration Test Points			
1 point			P1
2 points			P2
3 points			P3
4 points			P4
5 points			P5

SensyTemp TSP311, TSP321, TSP331

Temperature sensors

Additional ordering information SensyTemp TSP331	XX	XX	XX
Temperatures for Sensor Calibration			
Standard calibration: 0 °C (32 °F)	V1		
Standard calibration: 100 °C (212 °F)	V2		
Standard calibration: 400 °C (752 °F)	V3		
Standard calibration: 0 °C and 100 °C (32 °F and 212 °F)	V4		
Standard calibration: 0 °C and 400 °C (32 °F and 752 °F)	V5		
Standard calibration: 0 °C, 100 °C and 200 °C (32 °F, 212 °F and 392 °F)	V7		
Standard calibration: 0 °C, 200 °C and 400 °C (32 °F, 392 °F and 752 °F)	V8		
Standard calibration: Customer specific temperatures	V6		
DAkkS calibration: 0 °C (32 °F)	D1		
DAkkS calibration: 100 °C (212 °F)	D2		
DAkkS calibration: 400 °C (752 °F)	D3		
DAkkS calibration: 0 °C and 100 °C (32 °F and 212 °F)	D4		
DAkkS calibration: 0 °C and 400 °C (32 °F and 752 °F)	D5		
DAkkS calibration: 0 °C, 100 °C and 200 °C (32 °F, 212 °F and 392 °F)	D7		
DAkkS calibration: 0 °C, 200 °C and 400 °C (32 °F, 392 °F and 752 °F)	D8		
DAkkS calibration: Customer specific temperatures	D6		
Thermowell Options			
Thermowell stainless steel with additional tantalum sleeve			S1
Thermowell coated with 0.5 mm (0.02 in.) E-CTFE / Halar, wetted parts incl. flange surface			S2
Thermowell coated with 0.5 mm (0.02 in.) PFA, wetted parts incl. flange surface			S3
Thermowell coated with 1 mm (0.04 in.) NiCrB / META 43	2)		S4
Thermowell coated with 0.5 mm (0.02 in.) NiZrO2 / PL1312	2)		S5
Thermowell incl. tests and certificates AD-2000 standard for austenitic steel			S6
Thermowell incl. tests and certificates AD-2000 standard for high temperature steel			S7
Thermowell incl. tests and certificates NACE MR 01-75			S8
Thermowell clean for oxygen service			S9
Thermowell stress calculation according ASME 19.3-TW 2010 (Murdock)			SM
Thermowell with plug, gasket and chain			SP
Thermowell with plug and gasket			SR
Others			SZ
Flange Connection Options			
Flange raised face form RF, ASME B16.5			F6
Flange raised face form B1 acc. EN 1092-1			F7
Flange raised face form B2 acc. EN 1092-1			F8
Flange facing with tongue form C EN 1092-1			F1
Flange facing with groove form D acc. EN 1092-1			F2
Flange facing with RTJ surface acc. ASME B16.5			F3
Flange full penetration welded			F4
Others			FZ

Additional ordering information SensyTemp TSP331	XX	XX	XX	XX	XX	XX	XX
Extension Tube Options							
Extension tube welded with measuring inset, gas tight	N3						
Measuring Inset: Option							
Hot junction grounded	J1						
2 insets paired from 0 ... 100 °C (32 ... 212 °F), max. deviation 0.1 K	J3						
Improvement Sensor Accuracy to 0.5 Cl. A, 0 ... 100°C, U>100 mm	J8						
Improvement Sensor Accuracy to 0.5 Cl. A, 0 ... 400°C, U>250 mm	J9						
Measuring Inset: Transmitter Mounted							
Transmitter mounted on inset, without ceramic block				J2			
Measuring Inset: Other Options							
Others					JZ		
Connection Head Options							
Second transmitter mounted in connection head (same type as first one)						H1	
Cover of connection head with chain attached to the lower part						H8	
Connetion head with capstan screw for sealing						H9	
Others						HZ	
Cable Entry Options							
1 x M20 x 1.5, without cable gland							U1
1 x 1/2 in. NPT, without cable gland							U2
2 x M20 x 1.5, without cable gland							U4
2 x 1/2 in. NPT, without cable gland							U5
2x M20 x 1.5, with cable gland skintop, temperature range -40 bis +70 °C (-40 bis +158 °F)							U7
1 x M20 x 1.5, with Ex-d cable gland							UA
2 x M20 x 1.5, with Ex-d cable gland							UC
Harting Han 7D plug and socket connection							UG
Harting Han 8D (8U) plug and socket connection							UH
M12 plug for PROFIBUS PA							UJ
7/8 in. plug for FOUNDATION fieldbus							UK
1 x 1/2 in. NPT-PE ADE 4F Capri Codec							UF
1 x 1/2 in. NPT Capri Codec, with strain relief							UL
1 x 1/2 in. NPT-PE ADE 4F + 1 x 1/2 in. NPT plug							UP
Others							UZ
Display Type							
LCD indicator type AS							L1
Configurable LCD Indicator type A							L2

SensyTemp TSP311, TSP321, TSP331

Temperature sensors

Additional ordering information SensyTemp TSP331	XX	XX	XX	XX
Other Options				
Earth screw internal	PH			
Name plate stainless steel	PV			
Each Thermometer single packed - Polyethylen	PN			
Documentation Language				
German		M1		
English		M5		
Language package Western Europe / Scandinavia (Languages: DA, ES, FR, IT, NL, PT, FI, SV)		MW		
Language package Eastern Europe (Languages: EL, CS, ET, LV, LT, HU, HR, PL, SK, SL, RO, BG)		ME		
Additional TAG Plate				
Stainless steel plate with TAG no.				T1
Additional Identification Plate				
Stainless steel plate with customer specific text				T2
Adhesive label				T3

- 1) According EN 60079-0 and EN 61241-0, the application in hybrid mixtures (concomitance of potentially explosive dust and gas) is currently not allowed.
- 2) Specify length from thermowell tip in mm.

Trademarks

- ® HART is a registered trademark of FieldComm Group, Austin, Texas, USA
- ® PROFIBUS and PROFIBUS PA are registered trademarks of PROFIBUS & PROFINET International (PI)
- ® FOUNDATION Fieldbus is a registered trademark of FieldComm Group, Austin, Texas, USA
- ™ Hastelloy C-276 is a Cabot Corporation trademark
- ™ Hastelloy C-276 is a Haynes International trademark
- ™ Hastelloy C-4 is a Haynes International trademark
- ® Monel is a registered trademark of Special Metals Corporation

Notes

Contact us

ABB Limited

Process Automation

Howard Road, St. Neots
Cambridgeshire, PE19 8EU
UK

Tel: +44 (0)870 600 6122

Fax: +44 (0)1480 213 339

Mail: enquiries.mp.uk@gb.abb.com

ABB Inc.

Process Automation

125 E. County Line Road
Warminster, PA 18974
USA

Tel: +1 215 674 6000

Fax: +1 215 674 7183

ABB Automation Products GmbH

Process Automation

Schillerstr. 72
32425 Minden
Germany

Tel: +49 571 830-0

Fax: +49 571 830-1806

www.abb.com/temperature

Note

We reserve the right to make technical changes or modify the contents of this document without prior notice.

With regard to purchase orders, the agreed particulars shall prevail. ABB does not accept any responsibility whatsoever for potential errors or possible lack of information in this document.

We reserve all rights in this document and in the subject matter and illustrations contained therein. Any reproduction, disclosure to third parties or utilization of its contents – in whole or in parts – is forbidden without prior written consent of ABB.

Copyright© 2016 ABB

All rights reserved

3KXT161002R1001



Sales



Service